

Crane Scales

TABLE OF CONTENTS

MSI-3460 CHALLENGER 3	342
MSI-4260 PORT-A-WEIGH	344
MSI-4260 IS INTRINSICALLY SAFE CRANE SCALE PORT-A-WEIGH	346
MSI-4300 PORT-A-WEIGH PLUS	348
MSI-9300 PORT-A-WEIGH PLUS CELLSCALE™ RF	350
MSI-9300HT HI-TORQUE PORT-A-WEIGH PLUS CELLSCALE™ RF	352
MSI-6260CS TRANS-WEIGH CELLSCALE™ RF	354
MSI-7300 DYNA-LINK 2	356
<i>Digital Tension Dynamometer</i>	
MSI-CLAMP ON LOAD CELL	358
MSI-LOAD PIN SENSORS	359
MSI-LOAD PIN QUESTIONNAIRE	360
MSI SHEAR WEB LOAD CELL	361
MSI-TENSION LINK LOAD CELL	362
MSI-8004HD	364
<i>Indicator/RF LED Remote Display</i>	
MSI-8000	366
<i>RF Remote Display</i>	
MSI-8000HD	367
<i>Indicator/Remote Display</i>	
RF TRANSCEIVERS	
TRANSEND™	369
<i>Wireless Load Cell Interface System</i>	
MSI-9850 CELLSCALE™ RF DIGITAL INDICATOR	372
MSI-9750A CELLSCALE™ RF PORTABLE INDICATOR	374
MSI-9000 CELLSCALE™	375
MSI-9020 CELLSCALE™ RF CELLMODEM	377
MSI SCOREBOARDS WIRELESS RF	378
<i>Featuring LaserLight2 Remote Displays</i>	
SHACKLE DIMENSIONS	380

ESPAÑOL | Visit ricelake.com/spanish
to see all Rice Lake materials
available in Spanish

The following product names, logos, brands and other trademarks featured
or referred to within this publication are the property of their respective trademark holders.

MSI-3460 Challenger 3



Standard Features

- Crane unit with five-digit, 1.5 in (38 mm) LED display
- Top lifting eye or shackle and bottom swivel hook
- Lb/kg switch selectable
- Six volt rechargeable battery and universal 115/230 VAC, 50/60Hz battery charger (NA plug standard)

Additional Options

(Contact MSI for application consultation)

- Rugged remote control (control for Off, Zero, Tare and other functions)
- RF modem install for connectivity to MSI-8000, MSI-8000HD RF, MSI-8004HD RF remote display (100 ft line of sight)
- RF scoreboard
- NTEP Certified (250 lb-10,000 lb capacities)
- Universal direct power supply (115/230 VAC)
- Audible alarm
- Wi-Fi or Bluetooth® communications (additional use with MSI-ScaleCore Connect (available for download at Google Play Store))
- Potential receivers: MSI-8000, MSI-8000HD RF, MSI-8004HD RF, TranSend, LaserLight2



Optional rugged remote

Specifications

Accuracy:

± (0.1% or +1 d) of applied load

Resolution:

2,000 to 3,750 d standard (up to 10,000 d available)

Enclosure:

NEMA Type 4, IP65, powder coated cast aluminum

Lifting Eye & Hook:

Crosby® or equivalent with 360° non-bearing swivel hook

Design Overload:

200% Safe / 500% Ultimate

Functions:

Power: Turns unit on or off

Zero: Zeros applied load up to 100% of capacity (limited range in NTEP/OIML configurations)

Tare: Tares applied load and displays weight in Net mode User: Programmable as test, units, net/gross, total, peak hold and setpoints

Display:

Five-digit, 1.5 in (38 mm) LED with programmable brightness control

Displayable Units:

Pounds or kilogram selectable

Annunciators:

CO2, Net, Gross, Total, Peak, Low Battery, lb/kg, Motion, Setpoints, ack in, ack out, rf

Power:

6 volt rechargeable battery. 115/230 VAC battery charger is included

Operating Time:

Up to 80 hours between charging with typical use, less with optional RF Modem

Operating Temperature:

-40° F to 122° F (Industrial)

Auto-Off Mode:

Select for 15, 30, 45, 60 minutes or Off

Auto Sleep Mode:

Power down during non-use and power up with weight change or any key press

Service Counters:

Counts number of lifts over percentage of capacity and lifts over capacity

Calibration:

Digital

Filtering:

OFF, LO, HI-1, HI-2 selectable

Warranty:

One-year limited warranty

Approvals:

NTEP CC 86-021 - 250 lb-10,000 lb (125 kg-5,000 kg)

Approvals



pending



pending

Part Number/Price

Part #	MSI Part #	Description	Capacity	Resolution	Est. Weight	Price
139102	502887-0001	MSI-3460 250 lb/500 lb cap F/A	250 lb (125 kg) 500 lb (250 kg)	0.1 lb (0.05 kg) 0.2 lb (0.1 kg)	22 lb (10 kg)	\$1,890.00
139103	502887-0002	MSI-3460 1,000 lb/2,000 lb cap F/A	1,000 lb (500 kg) 2,000 lb (1,000 kg)	0.5 lb (0.2 kg) 1 lb (0.5 kg)	22 lb (10 kg)	\$1,990.00
139104	502887-0003	MSI-3460 5,000 lb/10,000 lb cap F/A	5,000 lb (2,500 kg) 10,000 lb (5,000 kg)	2 lb (1 kg) 5 lb (2 kg)	39 lb (18 kg)	\$2,495.00
139105	502887-0004	MSI-3460 15,000 lb cap F/A	15,000 lb (7,000 kg)	5 lb (2 kg)	67 lb (30 kg)	\$3,415.00
139110	502887-0005	MSI-3460 250 lb/500 lb cap F/A (with RF modem for connectivity to model MSI-8000 and remote)	250 lb (125 kg) 500 lb (250 kg)	0.1 lb (0.05 kg) 0.2 lb (0.1 kg)	22 lb (10 kg)	\$2,065.00
139111	502887-0010	MSI-3460 1,000 lb/2,000 lb cap F/A (with RF modem for connectivity to model MSI-8000 and remote)	1,000 lb (500 kg) 2,000 lb (1,000 kg)	0.5 lb (0.2 kg) 1 lb (0.5 kg)	22 lb (10 kg)	\$2,195.00
139112	502887-0011	MSI-3460 5,000 lb/10,000 lb cap F/A (with RF modem for connectivity to model MSI-8000 and remote)	5,000 lb (2,500 kg) 10,000 lb (5,000 kg)	2 lb (1 kg) 5 lb (2 kg)	39 lb (18 kg)	\$2,645.00
139113	502887-0012	MSI-3460 15,000 lb cap F/A (with RF modem for connectivity to model MSI-8000 and remote) Capacity: 15,000 lb (7,000 kg) Resolution: 5 lb (2 kg)	15,000 lb (7,000 kg)	5 lb (2 kg)	67 lb (30 kg)	\$3,620.00
176905 *	–	MSI-3460 250 lb/500 lb cap F/A with Bluetooth® RF	250 lb (125 kg) 500 lb (250 kg)	0.1 lb (0.05 kg) 0.2 lb (0.1 kg)	22 lb (10 kg)	Consult
176906 *	–	MSI-3460 1,000 lb/2,000 lb cap F/A with Bluetooth® RF	1,000 lb (500 kg) 2,000 lb (1,000 kg)	0.5 lb (0.2 kg) 1 lb (0.5 kg)	22 lb (10 kg)	Consult
176907 *	–	MSI-3460 5,000 lb/10,000 lb cap F/A with Bluetooth® RF	5,000 lb (2,500 kg) 10,000 lb (5,000 kg)	2 lb (1 kg) 5 lb (2 kg)	39 lb (18 kg)	Consult
176908 *	–	MSI-3460 15,000 lb cap F/A with Bluetooth® RF	15,000 lb (7,000 kg)	5 lb (2 kg)	67 lb (30 kg)	Consult
176909	–	MSI-3460 250 lb/500 lb cap F/A with Wi-Fi RF	250 lb (125 kg) 500 lb (250 kg)	0.1 lb (0.05 kg) 0.2 lb (0.1 kg)	22 lb (10 kg)	\$2,105.00
176910	–	MSI-3460 1,000 lb/2,000 lb cap F/A with Wi-Fi RF	1,000 lb (500 kg) 2,000 lb (1,000 kg)	0.5 lb (0.2 kg) 1 lb (0.5 kg)	22 lb (10 kg)	\$2,220.00
176911	–	MSI-3460 5,000 lb/10,000 lb cap F/A with Wi-Fi RF	5,000 lb (2,500 kg) 10,000 lb (5,000 kg)	2 lb (1 kg) 5 lb (2 kg)	39 lb (18 kg)	\$2,700.00
176912	–	MSI-3460 15,000 lb cap F/A with Wi-Fi RF	15,000 lb (7,000 kg)	5 lb (2 kg)	67 lb (30 kg)	\$3,695.00

* Bluetooth modems only work with certain Android devices. Please contact MSI for potential applications.

Options/Accessories

Part #	MSI Part #	Description	Est. Weight	Price
140049	C00502-0001	Battery assembly, 6 volt rechargeable	3 lb (1.4 kg)	\$120.00
139152	502956-0001	Universal 115/230 VAC, 50/60 Hz battery charger (NA plug standard)	5 lb (2.25 kg)	\$160.00
139153	502956-0002	Battery charger 115/230 VAC, 50/60 Hz (EC plug standard)	5 lb (2.25 kg)	\$160.00
149549	503486-0001	Universal 115/230 VAC 50/60 Hz (NA plug standard) battery charger for MSI-8000 remote display	3 lb (1.4 kg)	\$130.00
178004		LaserLight2, 4 in (101 mm) six-digit RF scoreboard	21 lb (10 kg)	\$2,035.00
178006		LaserLight2, 6 in (152 mm) six-digit RF scoreboard	37 lb (17 kg)	\$2,425.00
Consult		AC power supply		\$280.00
Consult		Audible setpoint alarm		\$300.00
139395		Retrofit kit 3460	1 lb	\$915.00
173014		Rugged remote control		\$280.00
139381	503208-0001	MSI-8000 RF remote display (requires MSI-3460 equipped with RF modem)	5 lb (2.25 kg)	\$1,135.00

MSI-4260 Port-A-Weigh



Standard Features

- Crane unit with five-digit, 1.2 in (30 mm) LED display
- Top lifting eye or shackle, bottom thrust bearing swivel hook
- 12 volt rechargeable battery and universal 115/230 VAC, 50/60 Hz battery charger (NA plug standard)

Additional Options

(Contact MSI for application consultation)

- Rugged remote control (control for Off, Zero, Tare and other functions)
- RF modem install for connectivity to MSI-8000, MSI-8000HD RF, MSI-8004HD RF remote display (100 ft line of sight)
- NTEP Certified configuration
- Anti-heat shielding for high temperature applications
- Substitute bottom swivel hook with shackle
- Oversized top lifting eye or shackle
- Oversized bottom hook
- Universal direct power supply; 85-265 VAC, 47-440 Hz / 130-300 VDC
- Low headroom top adapter
- Audible alarm
- Wi-Fi or Bluetooth® communications (additional use with MSI-ScaleCore Connect (available for download at Google Play Store))
- Potential receivers: MSI-8000, MSI-8000HD RF, MSI-8004HD RF, TranSend, LaserLight2
- Custom top and bottom interfaces
- Factory Mutual and ATEX approved Intrinsically Safe models available



Optional rugged remote

Specifications

Accuracy:

± (0.1% + 1 d) of applied load

Resolution:

3,000 to 5,000 d standard (up to 10,000 d available)

Enclosure:

NEMA Type 4, IP66 marine grade 356 alloy anodized cast aluminum

Lifting Eye, Shackle & Hook:

Crosby® or equal with 360° thrust-bearing swivel hook

Design Overload:

200% Safe / 500% Ultimate (except where noted)

Functions:

Power: Turns unit on or off

Zero: Zeros applied load up to 100% of capacity (limited range in NTEP Certified configuration)

Tare: Tares applied load and displays weight in Net mode F1: Programmable as test, units, net/gross, total and peak hold

Display:

Five-digit, 1.2 in (30 mm) LED with programmable brightness control

Displayable Units:

Pounds or kilograms selectable

Annunciators:

COZ, Net, Gross, Total, Peak, Low Battery, lb/kg, Motion, Setpoints

Power:

12 volt rechargeable battery. 115/230 VAC battery charger is included

Operating Time:

Up to 200 hours between charging with typical use, less with RF Modem option

Operating Temperature:

-40°F to 122°F (Industrial)

Auto-Off Mode:

Select for 15, 30, 45 minutes, 1 hour or Off

Auto Sleep Mode:

Power down during non-use and power up with weight change or any key press

Service Counters:

Counts number of lifts over percentage of capacity and lifts over capacity

Calibration:

Digital

Filtering:

OFF, LO, HI-1, HI-2 selectable

Warranty:

One-year limited warranty

Approvals:

NTEP CC 89-090 - 500 lb-2,000 lb (250 kg-1,000 kg)
NTEP CC 89-090A1 - 5,000 lb-70,000 lb (2,000 kg-35,000 kg)

Approvals



Part Number/Price

Part #	MSI Part #	Description	Capacity	Resolution	Est. Weight	Price
139460	503413-0001	MSI-4260B 500 lb F/A	500 lb (250 kg)	0.2 lb (0.1 kg)	53 lb (24 kg)	\$3,885.00
139461	503413-0002	MSI-4260B 2,000 lb F/A	2,000 lb (1,000 kg)	1.0 lb (0.5 kg)	53 lb (24 kg)	\$3,885.00
139462	503413-0003	MSI-4260B 5,000 lb F/A	5,000 lb (2,500 kg)	1.0 lb (0.5 kg)	62 lb (28 kg)	\$3,990.00
139463	503413-0004	MSI-4260B 10,000 lb F/A	10,000 lb (5,000 kg)	2.0 lb (1.0 kg)	62 lb (28 kg)	\$4,195.00
139464	503413-0005	MSI-4260B 20,000 lb F/A	20,000 lb (10,000 kg)	5.0 lb (2.0 kg)	105 lb (47 kg)	\$5,640.00
139465	503413-0006	MSI-4260B 30,000 lb F/A	30,000 lb (15,000 kg)	10 lb (5.0 kg)	125 lb (55 kg)	\$5,950.00
139466*	503413-0007	MSI-4260B 50,000 lb F/A	50,000 lb (25,000 kg)	10 lb (5.0 kg)	235 lb (106 kg)	\$8,705.00
139467**	503413-0008	MSI-4260B 70,000 lb F/A	70,000 lb (35,000 kg)	20 lb (10 kg)	270 lb (121 kg)	\$10,840.00
139468***	503413-0009	MSI-4260B 100,000 lb F/A	100,000 lb (50,000 kg)	20 lb (10 kg)	420 lb (189 kg)	\$17,050.00

Options/Accessories

Part #	MSI Part #	Description	Est. Weight	Price
150971	503508-0001	Option kit 4260B RF remote display (RF modem install for connectivity with MSI-8000 remote display and rugged remote)	N/A	\$199.00
139381	503208-0001	MSI-8000 RF remote display (requires MSI-4260 equipped with RF modem option 2)	5 lb (2.25 kg)	\$1,135.00
173014	N/A	RF rugged remote control (requires MSI-4260 equipped with RF modem)	N/A	\$280.00
153591	N/A	MSI-8000HD Remote Display, AC power and tilt bracket option	3 lb	\$1,240.00
159221	N/A	Universal crane scale transport cart	180 lb (82 kg)	\$970.00
178004	N/A	LaserLight2, 4 in (101 mm) six-digit RF scoreboard	21 lb (10 kg)	\$2,035.00
178006	N/A	LaserLight2, 6 in (152 mm) six-digit RF scoreboard	37 lb (17 kg)	\$2,425.00
Consult	N/A	AC direct power supply		\$485.00
Consult	N/A	Audible set point alarm		\$355.00
Consult	N/A	Anti-heat shield		\$910.00
152123	N/A	Retrofit kit 4260 to 4260B	8 lb	\$2,195.00
176956	N/A	Option kit, 4260B Wi-Fi RF	0 lb	\$395.00
Consult	N/A	Option kit, 4260B Bluetooth® RF	0 lb	Consult

Accessories				
150367	D00559-0004	Battery assembly, 12V rechargeable	7 lb (3 kg)	\$110.00
140994		Battery assembly		\$150.00
167777		Battery assembly, 12V		\$235.00
170606		Battery charger 12V SLA		\$265.00
138006	502221-0001	Universal 115/230 VAC, 50/60 Hz battery charger (NA plug standard)	4 lb (2 kg)	\$280.00
138007	502221-0002	Universal 115/230 VAC, 50/60 Hz battery charger (UK plug standard)	4 lb (2 kg)	\$280.00
138008	502221-0003	Universal 115/230 VAC, 50/60 Hz battery charger (EC plug standard)	4 lb (2 kg)	\$280.00
149549	503486-0001	Universal 115/ 230 VAC 50/60 Hz (NA plug standard) battery charger for MSI-8000 remote display	3 lb (1.4 kg)	\$130.00
4260 Sub Hook with Shackle				
Consult	N/A	500 to 10,000 lb, 6.5 ton shackle		NC
Consult	N/A	20,000 to 30,000 lb, 17 ton shackle		NC
Consult	N/A	50,000 lb, 25 ton shackle		\$1,500.00
Consult	N/A	70,000 lb, 40 ton shackle		\$2,100.00
Consult	N/A	100,000 lb, 55 ton shackle		\$6,000.00
4260 Oversize Lifting Eye/Shackle				
Consult	N/A	500 to 10,000 lb capacity		\$1,000.00
Consult	N/A	20,000 to 30,000 lb capacity, adapter with 25 ton shackle		\$1,320.00
Consult	N/A	50,000 to 70,000 lb capacity		Consult
Consult	N/A	100,000 lb capacity		Consult

* 490% of kg capacity

** 475% of lb capacity/430% of kg capacity

*** 450% of kg capacity

MSI-4260 IS Intrinsically Safe Crane Scale Port-A-Weigh



Standard Features

- Crane unit with five-digit, 1.2 in (30 mm) LED display
- Top lifting eye or shackle, bottom thrust bearing swivel hook
- 12 volt rechargeable battery and universal 115/230 VAC, 50/60 Hz battery charger (NA plug standard)

Additional Options

(Contact MSI for application consultation)

- NTEP Certified configuration

Approvals



Specifications

Accuracy:

± (0.1% +1 d) of applied load

Resolution:

3,000 to 5,000 d standard (up to 10,000 d available)

Enclosure:

NEMA Type 4, IP66 marine grade 356 alloy anodized cast aluminum

Intrinsic Safety:

US Listings

FM16US0156X

IS / I, II, III / 1 / CDEFG / T4 Ta = -20°C to 50°C

I / 0 / AEx ia / IIB / T4 Ta = -20°C to 50°C Ga

20 / AEx ia / IIIC / T135°C Ta = -20°C to 50°C Da

Canadian Listings

FM16CA0092X

IS / I, II, III / 1 / CD / T4 Ta = -10°C to 50°C

IS / II, III / 1 / EFG / T4 Ta = -10°C to 50°C

I / 0 / Ex ia / IIB / T4 Ta = -10°C to 50°C Ga

20 / Ex ia / IIIC / T135°C Ta = -10°C to 50°C Da

ATEX Listings

FM16ATEX0038X

II 1 G Ex ia IIB T4 Ga -10°C ≤ Ta ≤ 50°C

II 1 D Ex ia IIIC T135°C Da -10°C ≤ Ta ≤ 50°C

Lifting Eye, Shackle & Hook:

Crosby® or equal with 360° thrust-bearing swivel hook

Design Overload:

200% Safe / 500% Ultimate (except where noted)

Functions:

Power: Turns unit on or off

Zero: Zeros applied load up to 100% of capacity

(limited range in NTEP Certified configuration)

Tare: Tares applied load and displays weight in Net

mode F1: Programmable as test, units, net/gross, total and peak hold

Display:

Five-digit, 1.2 in (30 mm) LED with programmable brightness control

Displayable Units:

Pounds or kilograms selectable

Annunciators:

COZ, Net, Gross, Total, Peak, Low Battery, lb/kg, Motion, Setpoints

Power:

12 volt rechargeable battery.

115/230 VAC approved battery charger is included

Operating Time:

Up to 200 hours between charging with typical use

Auto-Off Mode:

Select for 15, 30, 45 minutes, 1 hour or Off

Auto Sleep Mode:

Power down during non-use and power up with weight change or any key press

Service Counters:

Counts number of lifts over percentage of capacity and lifts over capacity

Calibration:

Digital

Filtering:

OFF, LO, HI-1, HI-2 selectable

Warranty:

One-year limited warranty

Approvals:

NTEP CC 89-090 - 500 lb-2,000 lb (250 kg-1,000 kg)

NTEP CC 89-090A1 - 5,000 lb-70,000 lb

(2,000 kg-35,000 kg)

MSI-4260 IS Intrinsically Safe Crane Scale Port-A-Weigh

Part Number/Price

Part #	Description	Price
156013	500LB, Swivel Hook	\$5,665.00
156014	2K, Swivel Hook	\$5,665.00
156015	5K, Swivel Hook	\$5,775.00
156016	10K, Swivel Hook	\$5,990.00
156017	20K, Swivel Hook	\$7,175.00
156018	30K, Swivel Hook	\$7,495.00
156019	50K, Swivel Hook	\$9,975.00
156020	70K, Swivel Hook	\$12,020.00
156021	100K, Swivel Hook	\$18,910.00
156022	50K, No attachments	\$6,695.00
156023	70K, No Attachments	\$6,695.00
156024	100K, No Attachments	\$9,270.00

Options/Assessories

Part #	Description	Price
170606	Battery Charger	\$265.00
167777	Spare Battery	\$235.00

MSI-4300 Port-A-Weigh Plus



Standard Features

- Crane unit with six-digit, 1.6 in (40 mm), backlight, liquid crystal display
- Top lifting eye or shackle, bottom thrust bearing swivel hook
- 12 volt rechargeable battery and universal 115/230 VAC, 50/60 Hz battery charger (NA plug standard)

Additional Options

(Contact MSI for application consultation)

- D-cell battery option, provides up to 2,000 hours of operation
- Substitute bottom swivel hook with shackle
- Oversized top-lifting eye or shackle
- Oversized bottom hook
- Universal direct power supply; 85-265 VAC, 47-440 Hz / 130-300 VDC
- Low headroom top adapter
- Audible setpoint alarm
- NTEP Certified configuration
- Custom top and bottom interfaces
- Crane scale cart



Optional crane scale cart

Specifications

Accuracy:

± (0.1% +1 d) of applied load

Resolution:

3,000 to 5,000 d standard (up to 10,000 d available)

Enclosure:

NEMA Type 4, IP66, marine grade 356 alloy anodized cast aluminum

Top Lifting Eye, Shackle & Hook:

Crosby® or equal with 360° thrust-bearing swivel hook

Design Overload:

200% Safe / 500% Ultimate (except where noted)

Functions:

Power, zero, net/gross, tare and programmable test/user

Display:

Six-digit, 1.6 in (40 mm) LCD (upper) eight-digit, 0.8 in (20 mm) LCD (lower) with adjustable display contrast

Displayable Units:

Pounds, kilograms, tons, and metric tons selectable

Power:

12 volt rechargeable battery. 115/230VAC battery charger included

Operating Time:

300 hours with typical use

Operating Temperature:

14° F to 95° F (-10° C to 35° C)

Filtering:

OFF, LO, Medium and HI selectable

Warranty:

One-year limited warranty

Approvals:

NTEP CC 92-176 - 5,000 lb (2,500 kg)
Measurement Canada AM-4984

Approvals



Measurement
Canada
Approved

MSI-4300 Port-A-Weigh Plus

Part Number/Price

Part #	MSI Part #	Description	Capacity	Resolution	Est. Weight	Price
138825	502666-0013	MSI-4300 500 lb F/A	500 lb (250 kg)	0.2 lb (0.1 kg)	53 lb (24 kg)	\$4,515.00
138826	502666-0014	MSI-4300 2,000 lb F/A	2,000 lb (1000 kg)	1.0 lb (0.5 kg)	53 lb (24 kg)	\$4,515.00
138827	502666-0015	MSI-4300 5,000 lb F/A	5,000 lb (2500 kg)	1.0 lb (0.5 kg)	62 lb (28 kg)	\$4,630.00
138828	502666-0016	MSI-4300 10,000 lb F/A	10,000 lb (5000 kg)	2.0 lb (1.0 kg)	62 lb (28 kg)	\$4,865.00
138069	502235-0032	MSI-4300 20,000 lb F/A	20,000 lb (10,000 kg)	5.0 lb (2.0 kg)	105 lb (47 kg)	\$6,075.00
138070	502235-0033	MSI-4300 30,000 lb F/A	30,000 lb (15,000 kg)	10 lb (5.0 kg)	125 lb (55 kg)	\$6,385.00
138071*	502235-0034	MSI-4300 50,000 lb F/A	50,000 lb (25,000 kg)	10 lb (5.0 kg)	235 lb (106 kg)	\$8,945.00
138072**	502235-0035	MSI-4300 70,000 lb F/A	70,000 lb (35,000 kg)	20 lb (10 kg)	270 lb (121 kg)	\$11,045.00
138073***	502235-0036	MSI-4300 100,000 lb F/A	100,000 lb (50,000 kg)	20 lb (10 kg)	420 lb (189 kg)	\$18,075.00

Options/Accessories

Part #	MSI Part #	Description	Est. Weight	Price
159221	N/A	Universal crane scale transport cart	180 lb (82 kg)	\$970.00
Consult	N/A	Audible set point alarm		\$360.00
Consult	N/A	AC power supply		\$485.00
Consult	N/A	D cell battery option		Consult
Accessories				
150367	D00559-0004	Battery assembly, 12 volt rechargeable	7 lb (3 kg)	\$110.00
138006	502221-0001	Universal 115/230 VAC, 50/60 Hz battery charger (NA plug standard)	4 lb (2 kg)	\$280.00
138007	502221-0002	Universal 115/230 VAC, 50/60 Hz battery charger (UK plug standard)	4 lb (2 kg)	\$280.00
138008	502221-0003	Universal 115/230 VAC, 50/60 Hz battery charger (EC plug standard)	4 lb (2 kg)	\$280.00
4300 Sub Hook with Shackle				
Consult	N/A	500 to 10,000 lb, 6.5 ton shackle		NC
Consult	N/A	20,000 to 30,000 lb, 17 ton shackle		NC
Consult	N/A	50,000 lb, 25 ton shackle		-\$1,500.00
Consult	N/A	70,000 lb, 40 ton shackle		-\$2,100.00
Consult	N/A	100,000 lb, 55 ton shackle		-\$6,000.00
4300 Oversize Lifting Eye/Shackle				
Consult	N/A	500 to 10,000 lb capacity		\$1,000.00
Consult	N/A	20,000 to 30,000 lb capacity, adapter with 25 ton shackle		\$1,320.00
Consult	N/A	50,000 to 70,000 lb capacity		Consult
Consult	N/A	100,000 lb capacity		Consult

* 490% of kg capacity

** 475% of lb capacity/430% of kg capacity

*** 450% of kg capacity

MSI-9300 Port-A-Weigh Plus CellScale™ RF



Standard Features

- Crane unit with 2.4 GHz FHSS transceiver
- Six-digit, 30 mm (1.2 in.) LED display and annunciators
- Top lifting eye or shackle, and bottom thrust bearing swivel hook
- 12 volt rechargeable battery and universal 115/230 VAC, 50/60 Hz battery charger (NA plug standard)

Additional Options

(Contact MSI for application consultation)

- RF remote crane unit control, includes On/Off, Zero, Tare, Net/Gross, Total and programmable function keys
- Audible alarm
- Anti-heat shielding for high temperature applications
- Substitute bottom swivel hook with shackle
- Low headroom top adapter
- Oversized top lifting eye or shackle
- Oversized bottom hook
- Universal direct power supply; 85-265 VAC, 47-440 Hz / 130-300 VDC
- Wireless 802.11 b/g Ethernet connectivity
- MSI-9300 retrofit kit - conversion kit to upgrade existing MSI-4300 crane scale to 9300 RF unit
- Custom top and bottom interfaces
- Potential receivers: MSI-9850, 9750A, remote RF Indicators or LaserLight2 (each sold separately)
- Crane scale cart



Optional crane scale cart

Specifications

Accuracy:

± (0.1% + 1 d) of applied load

Resolution:

3,000 to 5,000 d standard (up to 10,000 d available)

Enclosure:

NEMA Type 4, IP66, marine grade 356 alloy anodized cast aluminum

Lifting Eye, Shackle & Hook:

Crosby® or equal with 360° thrust-bearing swivel hook.

Design Overload:

200% Safe / 500% Ultimate (except where noted)

Functions:

Power, zero, net/gross, tare and programmable test/user

Display:

Six-digit, 1.2 in (30 mm) LED with 14 feature annunciators and programmable brightness control

Displayable Units:

Pounds or kilograms selectable

Power:

12 volt rechargeable battery, 115-230 VAC battery charger included

Operating Time:

Up to 30 hours between charging with typical use

Operating Temperature:

-4° F to 140° F (-20° C to 60° C)

Calibration:

Digital via MSI-9750A or MSI-9850 RF indicators or via serial interface with PC terminal program

Filtering:

LO, Medium and HI selectable

Radio Link:

FHSS at 2.4 GHz

Radio Effective Range:

Typically 500 ft (150 m) indoor, 1,000 ft (300 m) outdoor with standard antennas

Warranty:

One-year limited warranty

Approvals:

NTEP CC 07-007; 5,000 lb-70,000 lb (2,500 kg-35,000 kg capacities)

Approvals



MSI-9300 Port-A-Weigh Plus CellScale™ RF

Part Number/Price

Part #	MSI Part #	Description	Capacity	Resolution	Est. Weight	Price
138704	502654-0001	MSI-9300 500 lb F/A	500 lb (250 kg)	0.2 lb (0.1 kg)	53 lb (24 kg)	\$6,175.00
138705	502654-0002	MSI-9300 2,000 lb F/A	2,000 lb (1,000 kg)	1.0 lb (0.5 kg)	53 lb (24 kg)	\$6,175.00
138706	502654-0003	MSI-9300 5,000 lb F/A	5,000 lb (2,500 kg)	1.0 lb (0.5 kg)	62 lb (28 kg)	\$6,285.00
138707	502654-0004	MSI-9300 10,000 lb F/A	10,000 lb (5,000 kg)	2.0 lb (1.0 kg)	62 lb (28 kg)	\$6,515.00
138409	502518-0005	MSI-9300 20,000 lb F/A	20,000 lb (10,000 kg)	5.0 lb (2.0 kg)	105 lb (47 kg)	\$7,720.00
138410	502518-0006	MSI-9300 30,000 lb F/A	30,000 lb (15,000 kg)	10 lb (5.0 kg)	125 lb (55 kg)	\$8,060.00
138419*	502518-0015	MSI-9300 50,000 lb F/A	50,000 lb (25,000 kg)	10 lb (5.0 kg)	235 lb (106 kg)	\$10,585.00
138420**	502518-0016	MSI-9300 70,000 lb F/A	70,000 lb (35,000 kg)	20 lb (10 kg)	270 lb (121 kg)	\$12,695.00
138421***	502518-0017	MSI-9300 100,000 lb F/A	100,000 lb (50,000 kg)	20 lb (10 kg)	420 lb (189 kg)	\$19,750.00

Options/Accessories

Part #	MSI Part #	Description	Est. Weight	Price
159625	N/A	MSI-9850 RF remote indicator (wall or desk mount)	10 lb (5 kg)	\$2,515.00
138486	502541-0001	MSI-9750 RF portable indicator	2 lb (1 kg)	\$1,885.00
Consult	N/A	LaserLight2, 4 in (101 mm) six-digit RF scoreboard	21 lb (10 kg)	Consult
Consult	N/A	LaserLight2, 6 in (152 mm) six-digit RF scoreboard	37 lb (17 kg)	Consult
138341	502488-0001	Universal mounting bracket for MSI-9850 RF remote indicator	2 lb (1 kg)	\$135.00
159221	N/A	Universal crane scale transport cart	180 lb (82 kg)	\$970.00
138298	502434-0001	RF remote controller	1 lb	\$310.00
138317	502452-0001	Spare RF remote	1 lb	\$110.00
Consult	N/A	AC power supply		\$485.00
Consult	N/A	Anti-heat shield		\$915.00
Consult	N/A	Audible alarm		\$360.00
Consult	N/A	Wi-Fi Ethernet option		\$335.00
138452	502520-0001	Retrofit kit 4300 D cell to 9300 12 Volt	1 lb	\$4,340.00
138453	502520-0002	Retrofit kit 4300 D cell to 9300 no modem	1 lb	\$3,445.00
138454	502520-0003	Retrofit kit 4300 to 9300	1 lb	\$3,925.00
138455	502520-0004	Retrofit kit 4300 to 9300 no modem	1 lb	\$2,945.00
9300 Sub Hook with Shackle				
Consult	N/A	500 to 10,000 lb, 6.5 ton shackle		NC
Consult	N/A	20,000 to 30,000 lb, 17 ton shackle		NC
Consult	N/A	50,000 lb, 25 ton shackle		-\$1,500.00
Consult	N/A	70,000 lb, 40 ton shackle		-\$2,100.00
Consult	N/A	100,000 lb, 55 ton shackle		-\$6,000.00
9300 Oversize Lifting Eye/Shackle				
Consult	N/A	500 to 10,000 lb capacity		\$1,000.00
Consult	N/A	20,000 to 30,000 lb capacity, adapter with 25 ton shackle		\$1,320.00
Consult	N/A	50,000 to 70,000 lb capacity		Consult
Consult	N/A	100,000 lb capacity		Consult
Accessories				
150367	D00559-0004	Battery assembly, 12 volt rechargeable	7 lb (3 kg)	\$110.00
148624	501705-0001	RS-232/RS-485 serial cable	1 lb (0.45 kg)	\$110.00
138006	502221-0001	Universal 115/230 VAC, 50/60 Hz battery charger (NA plug standard)	4 lb (2 kg)	\$280.00
138007	502221-0002	Universal 115/230 VAC, 50/60 Hz battery charger (UK plug standard)	4 lb (2 kg)	\$280.00
138008	502221-0003	Universal 115/230 VAC, 50/60 Hz battery charger (EC plug standard)	4 lb (2 kg)	\$280.00

* 490% of kg capacity

** 475% of lb capacity/430% of kg capacity

*** 450% of kg capacity

MSI-9300HT Hi-Torque Port-A-Weigh Plus CellScale™ RF



Standard Features

- Crane unit with 2.4 GHz spread spectrum transceiver
- Six-digit, 30 mm (1.2 in) LED display and annunciators
- Top shackle interface and fixed bottom hook (Note: Top shackle not included; see Options)
- 12 volt rechargeable battery and universal 115/230 VAC, 50/60 Hz battery charger (NA plug standard)
- Hi-torque load train designed for use with powered rotation

Additional Options

(Contact MSI for application consultation)

- RF remote crane unit control, includes On/Off, Zero, Tare, Net/Gross, Total, and programmable function keys
- Anti-heat shielding for high temperature applications
- Substitute bottom hook with shackle
- Oversized top or shackle
- Oversized bottom hooks
- Universal direct power supply; 85-265 VAC, 47-440 Hz / 130-300 VDC
- Wireless 802.11 b/g Ethernet connectivity
- Low headroom top adaptor
- Top shackle
- Audible alarm
- Custom top and bottom interfaces
- Potential receivers: MSI-9850, 9750A, remote RF Indicators or LaserLight2 (each sold separately)

Specifications

Accuracy:

± (0.1% + 1 d) of capacity

Resolution:

3,000 to 5,000 d standard (up to 10,000 d available)

Enclosure:

NEMA Type 4, IP66, marine grade 356 alloy anodized cast aluminum

Lifting Eye, Shackle & Hook:

Shackle is optional and Crosby® fixed hook provided as standard.

Design Overload:

200% Safe / 500% Ultimate

Functions:

Power, zero, net/gross, tare and programmable test/user

Display:

Six-digit, 1.2 in (30 mm) LED with 14 feature annunciators and programmable brightness control

Displayable Units:

Pounds or kilograms selectable

Power:

12 volt rechargeable battery, 115-230 VAC battery charger included

Operating Time:

Up to 30 hours between charging with typical use

Operating Temperature:

-4° F to 140° F (-20° C to 60° C)

Calibration:

Digital via MSI-9750A or MSI-9850 RF indicators or via serial interface with PC terminal program.

Filtering:

LO, Medium and HI selectable

Radio Link:

FHSS at 2.4 GHz

Radio Effective Range:

Typically 500 ft (150 m) indoor, 1,000 ft (300 m) outdoor with standard antennas.

Warranty:

One-year limited warranty

MSI-9300HT Hi-Torque Port-A-Weigh Plus CellScale™ RF

Part Number/Price

Part #	MSI Part #	Description	Capacity	Resolution	Est. Weight	Price
138440	502519-0001	MSI-9300HT 30,000 lb F/A	30,000 lb (15,000 kg)	10 lb (5.0 kg)	125 lb (55 kg)	\$13,900.00
138441	502519-0002	MSI-9300HT 70,000 lb F/A	70,000 lb (35,000 kg)	20 lb (10 kg)	270 lb (121 kg)	\$17,225.00
162377	N/A	MSI-9300HT 120,000 lb F/A	120,000 lb (60,000 kg)	50 lb (20 kg)	550 lb (250 kg)	Consult

Options/Accessories

Part #	MSI Part #	Description	Est. Weight	Price
141992	10539	Top lifting shackle Crosby® G2130 17 ton for 30,000 lb cap unit	19.5 lb (8.9 kg)	\$340.00
146335	23650-0040	Top lifting shackle Crosby® G2140 40 ton for 70,000 lb cap unit	34 lb (15 kg)	\$970.00
146336	23650-0050	Top lifting shackle Crosby® G2140 55 ton* for 120,000 lb cap unit	104 lb (47 kg)	\$1,485.00
159625	N/A	MSI-9850 RF remote indicator (wall or desk mount)	10 lb (5 kg)	\$2,515.00
138486	502541-0001	MSI-9750 RF portable Indicator	2.2 lb (1 kg)	\$1,885.00
Consult	N/A	LaserLight2, 4 in (101 mm) six-digit RF scoreboard	21 lb (10 kg)	Consult
Consult	N/A	LaserLight2, 6 in (152 mm) six-digit RF scoreboard	37 lb (17 kg)	Consult
138341	502488-0001	Universal mounting bracket for MSI-9850 RF remote indicator	2.2 lb (1 kg)	\$135.00
159221	N/A	Universal crane scale transport cart	180 lb (82 kg)	\$970.00
138298	502434-0001	RF remote controller	1 lb (0.45 kg)	\$310.00
138317	502452-0001	Spare RF remote	1 lb (0.45 kg)	\$110.00
Consult	N/A	AC direct power supply		\$485.00
Consult	N/A	Anti-heat shield		\$915.00
Consult	N/A	Audible alarm		\$360.00
Consult	N/A	Wi-Fi Ethernet option		\$335.00
Accessories				
148624	501705-0001	RS-232/RS-485 serial cable	1 lb (0.45 kg)	\$110.00
150367	D00559-0004	Battery assembly, 12 volt rechargeable	6.6 lb (3 kg)	\$110.00
138006	502221-0001	Universal 115/230 VAC, 50/60 Hz battery charger (NA plug standard)	4 lb (2 kg)	\$280.00
138007	502221-0002	Universal 115/230 VAC, 50/60 Hz battery charger (UK plug standard)	4 lb (2 kg)	\$280.00
138008	502221-0003	Universal 115/230 VAC, 50/60 Hz battery charger (EC plug standard)	4 lb (2 kg)	\$280.00

* 55 Metric Tons = 121,254 lbs

MSI-6260CS Trans-Weigh CellScale™ RF



Standard Features

- Crane unit with 2.4 GHz spread spectrum transceiver
- Top lifting eye or shackle, and bottom thrust bearing swivel hook
- 12 volt rechargeable battery and universal 115/230 VAC, 50/60 Hz battery charger (NA plug standard)

Additional Options

(Contact MSI for application consultation)

- NTEP Certified configuration
- ScaleCore configurations available
- Anti-heat shielding for high temperature applications
- Substitute bottom swivel hook with shackle
- Oversized top lifting eye or shackle
- Oversized bottom hook
- Low headroom top adaptor
- Universal direct power supply; 85-265 VAC, 47-440 Hz / 130-300 VDC
- Wireless 802.11 b/g Ethernet connectivity
- MSI-6260CS retrofit kit - conversion kit to upgrade existing MSI-4260 crane scales to MSI-6260CS
- Custom top and bottom interfaces
- Potential receivers: MSI-9850, 9750A, remote RF Indicators or LaserLight2 (Each sold separately.)
- Crane scale cart



Optional crane scale cart

Specifications

Accuracy:

± (0.1% + 1 d) of applied load

Resolution:

3,000 to 5,000 d standard (up to 10,000 d available)

Enclosure:

NEMA Type 4, IP66, marine grade 356 alloy anodized cast aluminum

Lifting Eye, Shackle & Hook:

Crosby® or equivalent with 360° thrust-bearing swivel hook

Design Overload:

200% Safe / 500% Ultimate (except where noted)

Functions:

Power on/off (all other scale functions are controlled from other optional networked MSI scale indicators MSI-9850 and/or MSI-9750A)

Displayable Units:

Pounds or kilograms selectable

Power:

12 volt rechargeable battery, 115/230 VAC battery charger included

Operating Time:

Up to 40 hours between charging with typical use

Operating Temperature:

-4° F to 140° F (-20° C to 60° C)

Calibration:

Digital via MSI-9750A or MSI-9850 RF indicators or via serial interface with PC terminal program

Radio Link:

FHSS at 2.4 GHz

Radio Link Effective Range:

Typically 500 ft (150 m) indoor, 1,000 ft (300 m) outdoor with standard antennas

Warranty:

One-year limited warranty

Approvals:

NTEP CC 07-007: 5,000 to 70,000 lb (2,500 kg to 35,000 kg)

Approvals



MSI-6260CS Trans-Weigh CellScale™ RF

Part Number/Price

Part #	MSI Part #	Description	Capacity	Resolution	Est. Weight	Price
138729	502655-0001	MSI-6260 500 lb F/A	500 lb (250 kg)	0.2 lb (0.1 kg)	53 lb (24 kg)	\$4,935.00
138730	502655-0002	MSI-6260 2,000 lb F/A	2,000 lb (1000 kg)	1.0 lb (0.5 kg)	53 lb (24 kg)	\$4,935.00
138731	502655-0003	MSI-6260 5,000 lb F/A	5,000 lb (2500 kg)	1.0 lb (0.5 kg)	62 lb (28 kg)	\$5,035.00
138732	502655-0004	MSI-6260 10,000 lb F/A	10,000 lb (5000 kg)	2.0 lb (1.0 kg)	62 lb (28 kg)	\$5,250.00
138506	502559-0005	MSI-6260 20,000 lb F/A	20,000 lb (10,000 kg)	5.0 lb (2.0 kg)	105 lb (47 kg)	\$6,400.00
138507	502559-0006	MSI-6260 30,000 lb F/A	30,000 lb (15,000 kg)	10 lb (5.0 kg)	125 lb (55 kg)	\$6,715.00
138508*	502559-0007	MSI-6260 50,000 lb F/A	50,000 lb (25,000 kg)	10 lb (5.0 kg)	235 lb (106 kg)	\$9,135.00
138509**	502559-0008	MSI-6260 70,000 lb F/A	70,000 lb (35,000 kg)	20 lb (10 kg)	270 lb (121 kg)	\$11,130.00
138510***	502559-0009	MSI-6260 100,000 lb F/A	100,000 lb (50,000 kg)	20 lb (10 kg)	420 lb (189 kg)	\$17,835.00

Options/Accessories

Part #	MSI Part #	Description	Est. Weight	Price
159625	N/A	MSI-9850 RF remote indicator (wall or desk mount)	10 lb (5 kg)	\$2,515.00
138486	502541-0001	MSI-9750 RF portable indicator	2.2 lb (1 kg)	\$1,885.00
138341	502488-0001	Universal mounting bracket for MSI-9850 RF remote indicator	2.2 lb (1 kg)	\$135.00
159221	N/A	Universal crane scale transport cart	180 lb (82 kg)	\$970.00
Consult	N/A	LaserLight2, 4 in (101 mm) six-digit RF scoreboard	21 lb (10 kg)	Consult
Consult	N/A	LaserLight2, 6 in (152 mm) six-digit RF scoreboard	37 lb (17 kg)	Consult
Consult	N/A	AC power supply		\$485.00
Consult	N/A	Anti-heat shield		\$915.00
Consult	N/A	Audible alarm		\$360.00
Consult	N/A	Wi-Fi Ethernet option		\$335.00
138575	N/A	Retrofit kit 4260 to 6260 CS	1 lb (0.45 kg)	\$2,695.00
6260 Sub Hook with Shackle				
Consult	N/A	500 to 10,000 lb, 6.5 ton shackle		Consult
Consult	N/A	20,000 to 30,000 lb, 17 ton shackle		Consult
Consult	N/A	50,000 lb, 25 ton shackle		-\$1,500.00
Consult	N/A	70,000 lb, 40 ton shackle		-\$2,100.00
Consult	N/A	100,000 lb, 55 ton shackle		-\$6,000.00
6260 Oversize Lifting Eye/Shackle				
Consult	N/A	500 to 10,000 lb capacity		\$1,000.00
Consult	N/A	20,000 to 30,000 lb capacity, adapter with 25 ton shackle		\$1,320.00
Consult	N/A	50,000 to 70,000 lb capacity		Consult
Consult	N/A	100,000 lb capacity		Consult
Accessories				
148624	501705-0001	RS-232/RS-485 serial cable	1 lb (0.45 kg)	\$110.00
150367	D00559-0004	Battery assembly, 12 volt rechargeable	6.6 lb (3 kg)	\$110.00
138006	502221-0001	Universal 115/230 VAC, 50/60 Hz battery charger (NA plug standard)	4 lb (2 kg)	\$280.00
138007	502221-0002	Universal 115/230 VAC, 50/60 Hz battery charger (UK plug standard)	4 lb (2 kg)	\$280.00
138008	502221-0003	Universal 115/230 VAC, 50/60 Hz battery charger (EC plug standard)	4 lb (2 kg)	\$280.00

* 490% of kg capacity

** 475% of lb capacity/430% of kg capacity

*** 450% of kg capacity

MSI-7300 Dyna-Link 2

Digital Tension Dynamometer



Optional rugged remote

Standard Features

- Tension dynamometer with six-digit, 1.00 in (25.4 mm) LCD display
- Two C alkaline batteries for capacities up to 10,000 lb (5,000 kg)
- Two D alkaline batteries for capacities 25,000 lb (12,500 kg) and above

Additional Options

(Contact MSI for application consultation)

- Crosby® top and bottom shackles
- Portable transport case
- Serial output cable
- Rugged remote control (control for Off, Zero, Tare and other functions)
- RF modem install for connectivity to MSI-8000, MSI-8000HD RF, MSI-8004HD RF remote display (100 ft line of sight)
- Heavy capacity configurations (60 to 275 Ton)
- Audible alarm
- Wi-Fi or Bluetooth® communications (additional use with MSI-ScaleCore Connect (available for download at Google Play Store))
- Potential receivers: MSI-8000, MSI-8000HD RF, MSI-8004HD RF, TranSend, LaserLight2

Part Number/Price

Part #	MSI Part #	Description	Capacity	Resolution	Est. Weight	Price
139162	502967-0001	MSI-7300 1,000 lb F/A	1,000 lb (500 kg)	0.5 lb (0.2 kg)	8 lb (3.6 kg)	\$1,455.00
139163	502967-0002	MSI-7300 2,500 lb F/A	2,500 lb (1,250 kg)	1 lb (0.5 kg)	9 lb (4.0 kg)	\$1,455.00
139164	502967-0003	MSI-7300 5,000 lb F/A	5,000 lb (2,500 kg)	2 lb (1.0 kg)	9 lb (4.0 kg)	\$1,455.00
139165	502967-0004	MSI-7300 10,000 lb F/A	10,000 lb (5,000 kg)	5 lb (2.0 kg)	11 lb (5.0 kg)	\$1,555.00
139166	502967-0005	MSI-7300 25,000 lb F/A	25,000 lb (12,500 kg)	10 lb (5 kg)	19 lb (8.6 kg)	\$2,090.00
139167	502967-0006	MSI-7300 50,000 lb F/A	50,000 lb (25,000 kg)	20 lb (10 kg)	29 lb (13 kg)	\$2,705.00
139168*	502967-0007	MSI-7300 100,000 lb F/A	100,000 lb (50,000 kg)	50 lb (20 kg)	65 lb (30 kg)	\$3,535.00
Optional Configurations (for connectivity to MSI-8000 RF Remote Display) F/A						
139441	503381-0001	MSI-7300 RF module	1,000 lb (500 kg)	0.5 lb (.2 kg)	8 lb (3.6 kg)	\$1,635.00
139442	503381-0002	MSI-7300 RF module	2,500 lb (1,250 kg)	1 lb (.5 kg)	9 lb (4 kg)	\$1,635.00
139443	503381-0003	MSI-7300 RF module	5,000 lb (2,500 kg)	2 lb (1 kg)	9 lb (4 kg)	\$1,635.00
139444	503381-0004	MSI-7300 RF module	10,000 lb (5,000 kg)	5 lb (2 kg)	11 lb (5 kg)	\$1,740.00
139445	503381-0005	MSI-7300 RF module	25,000 lb (12,500 kg)	10 lb (5 kg)	19 lb (8.6 kg)	\$2,260.00
139446	503381-0006	MSI-7300 RF module	50,000 lb (25,000 kg)	20 lb (10 kg)	29 lb (13 kg)	\$2,880.00
139447*	503381-0007	MSI-7300 RF module	100,000 lb (50,000 kg)	50 lb (20 kg)	65 lb (30 kg)	\$3,720.00
159168*	N/A	MSI-7300 RF module	120,000 lb (60,000 kg)	50 lb (20 kg)	57 lb (26 kg)	\$4,785.00
159169*	N/A	MSI-7300 RF module	180,000 lb (90,000 kg)	100 lb (50 kg)	74 lb (36 kg)	\$7,280.00
159170*	N/A	MSI-7300 RF module	260,000 lb (130,000 kg)	100 lb (50 kg)	100 lb (45 kg)	\$9,740.00
159171*	N/A	MSI-7300 RF module	380,000 lb (190,000 kg)	200 lb (100 kg)	169 lb (77 kg)	\$11,025.00

Specifications

Accuracy:

- 0.1% FS of rated capacity (up to 50 ton)
- 0.5% FS of rated capacity (50 ton and above)

Enclosure:

NEMA Type 4, IP65, anodized corrosion-resistant finish

Material:

2024 aircraft grade aluminum
Capacities above 100 K have zinc plated enclosures and 4340 load cell bodies

Design Overload:

200% Safe/700% Ultimate* (except where noted)

Functions:

On/Off, Zero, Hi-Speed Peak Hold, Setpoints, Total, Tare, Auto-Off, Motion Filter

Display:

Six-digit, 1.00 in (25.4 mm) LCD

Displayable Units:

Pounds, kilograms, kilonewtons, tons, metric tons

LED Annunciators:

Function 1, Function 2, Setpoint 1, Setpoint 2

LCD Annunciators:

Net, Center of Zero, Stable, Battery Test, Peak Hold, Total

Power:

Two C alkaline batteries for capacities up to 10,000 lb two D alkaline batteries for capacities 25,000 lb–100,000 lb

Operating Time:

From 150 to 300 hours in typical use depending on unit capacity and battery configuration. Approximately 25 to 30 hours with optional RF modem link installed.

Operating Temperature:

- 40° F to 122° F (Industrial)

Calibration:

Digital

Filtering:

OFF, LO, HI selectable

Data Output:

Serial RS-232

Warranty:

Two-year limited warranty

MSI-7300 Dyna-Link 2

Digital Tension Dynamometer

Part Number/Price

Part #	MSI Part #	Description	Capacity	Resolution	Est. Weight	Price
159172**	N/A	MSI-7300 RF module	550,000 lb (275,000 kg)	200 lb (100 kg)	336 lb (152 kg)	\$20,800.00
176806	N/A	MSI-7300 1,000 lb F/A with Bluetooth® RF ***	1,000 lb (500 kg)	0.5 lb (0.2 kg)	8 lb (3.6 kg)	Consult
176807	N/A	MSI-7300 2,500 lb F/A with Bluetooth® RF ***	2,500 lb (1,250 kg)	1 lb (0.5 kg)	9 lb (4.0 kg)	Consult
176808	N/A	MSI-7300 5,000 lb F/A with Bluetooth® RF ***	5,000 lb (2,500 kg)	2 lb (1.0 kg)	9 lb (4.0 kg)	Consult
176809	N/A	MSI-7300 10,000 lb F/A with Bluetooth® RF ***	10,000 lb (5,000 kg)	5 lb (2.0 kg)	11 lb (5.0 kg)	Consult
176810	N/A	MSI-7300 25,000 lb F/A with Bluetooth® RF ***	25,000 lb (12,500 kg)	10 lb (5 kg)	19 lb (8.6 kg)	Consult
176811	N/A	MSI-7300 50,000 lb F/A with Bluetooth® RF ***	50,000 lb (25,000 kg)	20 lb (10 kg)	29 lb (13 kg)	Consult
176812	N/A	MSI-7300 100,000 lb F/A with Bluetooth® RF ***	100,000 lb (50,000 kg)	50 lb (20 kg)	65 lb (30 kg)	Consult
176813	N/A	MSI-7300 1,000 lb F/A with Wi-Fi RF	1,000 lb (500 kg)	0.5 lb (0.2 kg)	8 lb (3.6 kg)	\$1,660.00
176814	N/A	MSI-7300 2,500 lb F/A with Wi-Fi RF	2,500 lb (1,250 kg)	1 lb (0.5 kg)	9 lb (4.0 kg)	\$1,660.00
176815	N/A	MSI-7300 5,000 lb F/A with Wi-Fi RF	5,000 lb (2,500 kg)	2 lb (1.0 kg)	9 lb (4.0 kg)	\$1,660.00
176816	N/A	MSI-7300 10,000 lb F/A with Wi-Fi RF	10,000 lb (5,000 kg)	5 lb (2.0 kg)	11 lb (5.0 kg)	\$1,775.00
176817	N/A	MSI-7300 25,000 lb F/A with Wi-Fi RF	25,000 lb (12,500 kg)	10 lb (5 kg)	19 lb (8.6 kg)	\$2,300.00
176818	N/A	MSI-7300 50,000 lb F/A with Wi-Fi RF	50,000 lb (25,000 kg)	20 lb (10 kg)	29 lb (13 kg)	\$3,010.00
176819	N/A	MSI-7300 100,000 lb F/A with Wi-Fi RF	100,000 lb (50,000 kg)	50 lb (20 kg)	65 lb (30 kg)	\$3,790.00
176822*	N/A	MSI-7300 120,000 lb F/A with Bluetooth® RF ***	120,000 lb (60,000 kg)	50 lb (20 kg)	57 lb (26 kg)	Consult
176823	N/A	MSI-7300 180,000 lb F/A with Bluetooth® RF ***	180,000 lb (90,000 kg)	100 lb (50 kg)	74 lb (36 kg)	Consult
176824	N/A	MSI-7300 260,000 lb F/A with Bluetooth® RF ***	260,000 lb (130,000 kg)	100 lb (50 kg)	100 lb (45 kg)	Consult
176825	N/A	MSI-7300 380,000 lb F/A with Bluetooth® RF ***	380,000 lb (190,000 kg)	200 lb (100 kg)	169 lb (77 kg)	Consult
176826**	N/A	MSI-7300 550,000 lb F/A with Bluetooth® RF ***	550,000 lb (275,000 kg)	200 lb (100 kg)	336 lb (152 kg)	Consult
176827	N/A	MSI-7300 120,000 lb F/A with Wi-Fi RF	120,000 lb (60,000 kg)	50 lb (20 kg)	57 lb (26 kg)	\$4,870.00
176828	N/A	MSI-7300 180,000 lb F/A with Wi-Fi RF	180,000 lb (90,000 kg)	100 lb (50 kg)	74 lb (36 kg)	\$7,420.00
176829	N/A	MSI-7300 260,000 lb F/A with Wi-Fi RF	260,000 lb (130,000 kg)	100 lb (50 kg)	100 lb (45 kg)	\$9,920.00
176830	N/A	MSI-7300 380,000 lb F/A with Wi-Fi RF	380,000 lb (190,000 kg)	200 lb (100 kg)	169 lb (77 kg)	\$11,245.00
176831	N/A	MSI-7300 550,000 lb F/A with Wi-Fi RF	550,000 lb (275,000 kg)	200 lb (100 kg)	336 lb (152 kg)	\$20,800.00

* 500% Ultimate overload

** 440% Ultimate overload

*** Bluetooth modems only work with certain Android devices. Please contact MSI for potential applications.

Options/Accessories

Part #	MSI Part #	Description	Est. Weight	Price
151357	10541	Shackle anchor, bolt type 3.25 ton for 500 lb-5,000 lb unit	3 lb (1.4 kg)/pair	Consult
151355	10538	Shackle anchor, bolt type 6.5 ton for 10,000 lb unit	6 lb (2.7 kg)/pair	Consult
141992	10539	Shackle anchor, bolt type 17 ton for 25,000 lb unit	39 lb (17.7 kg)/pair	Consult
151356	10540	Shackle anchor, bolt type 25 ton for 50,000 lb unit	63 lb (28.6 kg)/pair	Consult
146336	23650-0050	Shackle anchor, bolt type 55 ton for 100,000 lb unit	180 lb (82 kg)/pair	Consult
151359	N/A	Shackle anchor, bolt type 85 ton for 180,000 lb unit	206 lb (93 kg)/pair	Consult
151360	N/A	Shackle anchor, bolt type 120 ton for 260,000 lb unit	225 lb (102 kg)/pair	Consult
151361	N/A	Shackle anchor, bolt type 175 ton for 380,000 lb unit	665 lb (590 kg)/pair	Consult
151358	N/A	Shackle anchor, bolt type 250 ton for 550,000 lb unit	1,300 lb (318 kg)/pair	Consult
139381	503208-0001	MSI-8000 RF remote display (requires MSI-7300 equipped with optional RF modem)	5 lb (2.25 kg)	\$1,135.00
153591	N/A	MSI-8000HD RF remote display, A/C powered with tilt stand	5 lb (2.25 kg)	\$1,240.00
165313	N/A	Heavy duty pelican transport case with precision cut Heavy duty foam for 500 lb-10,000 lb capacity units	10 lb	\$310.00
145076	14317	Transport crate for 25,000 lb and 50,000 lb capacity unit	35 lb	\$375.00
145073	14311	Transport crate for 100,000 lb capacity unit	42 lb	\$375.00
139470	503414-0002	RS-232 serial cable for MSI-7300	1 lb (0.45 kg)	\$130.00
178004	N/A	LaserLight2, 4 in (101 mm) six-digit RF scoreboard	21 lb (10 kg)	\$2,035.00
178006	N/A	LaserLight2, 6 in (152 mm) six-digit RF scoreboard	37 lb (17 kg)	\$2,425.00
149549	503486-0001	Universal 115/ 230 VAC 50/60 Hz (NA plug standard) battery charger for MSI-8000 remote display	3 lb (1.4 kg)	\$130.00
182223		12V car charger adapter for MSI-8000	1 lb	\$110.00
173014		Rugged remote control	N/A	\$280.00
150964	503489-0001	RS-232 13 ft (4 m) serial cable for MSI-8000	1 lb (0.45 kg)	\$160.00
139438	N/A	Audible set point	N/A	\$360.00
149550	503486-0002	Battery charger for MSI-8000 EC plug	N/A	\$125.00

MSI-Clamp On Load Cell



Specifications

- Accuracy:**
3-5% of rated capacity
- Material:**
ETD 150
- IP Rating:**
IP68
- Cable Length:**
20 ft. (6 m.) integral cable with blunt end termination
- Cable Color Code:**
 - Red+ Excitation
 - Black.....- Excitation
 - Green+ Signal
 - White- Signal

Standard Features

- ETD 150 Construction
- Accommodates up to 3/4" wire rope size
- IP68
- Larger diameter clamp ons available - call for pricing

Options

- Custom sizes available on request
- Pair with an SCT transmitter for basic safety functions

Part Number/Price

Part #	Description	Price
179080	Load Cell Assembly Clamp-On for 3/8 to 1/2 in wire rope	\$675.00
179082	Load Cell Assembly Clamp-On for 9/16 to 3/4 in wire rope	\$800.00
188816	Kit with SCT-2200 for 3/8 to 1/2 in wire rope	\$1,200.00
188817	Kit with SCT-2200 for 9/16 to 3/4 in wire rope	\$1,330.00

Larger diameter clamp ons available - call for pricing

Dimensions

Cable Range	P/N	A	B	C
3/8 - 1/2	179080	Cable + 1.70	6.00	2.00
9/16-3/4	179082	Cable + 1.67	6.00	2.00

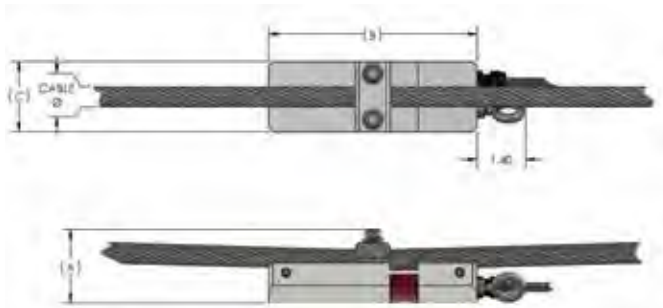



Standard Features

- Internally gauged load pin
- Idler sheave or dead end pin preferred location
- Minimum 5:1 safety factor
- 17-4 stainless steel construction
- $\pm 1\%$ to 3% accuracy of hoist capacity
- -40°F to 140°F standard operating temperature (other temperature compensated ranges available)

A key component for MSI's integrated overhead weighing solutions is the Load Pin Sensor. Typically designed and manufactured specifically to each integrated solution, the MSI load pin is strictly industrial grade. Each load pin design is precision machined from 17-4 stainless steel for safety, strength and corrosion resistance.

Each strain gauge location is precisely calculated and correctly placed in the optimum concentrated stress area of each installation. This MSI applied engineering process ensures the most efficient and accurate performance for each specific installation.

MSI load pin designs apply only internally mounted strain gauges for complete protection from the outside environment.

To receive a quotation for a load pin sensor to meet your application requirements, complete the load pin questionnaire also located at www.ricelake.com or contact an MSI overhead weighing specialist for further application assistance.

MSI-Load Pin Questionnaire

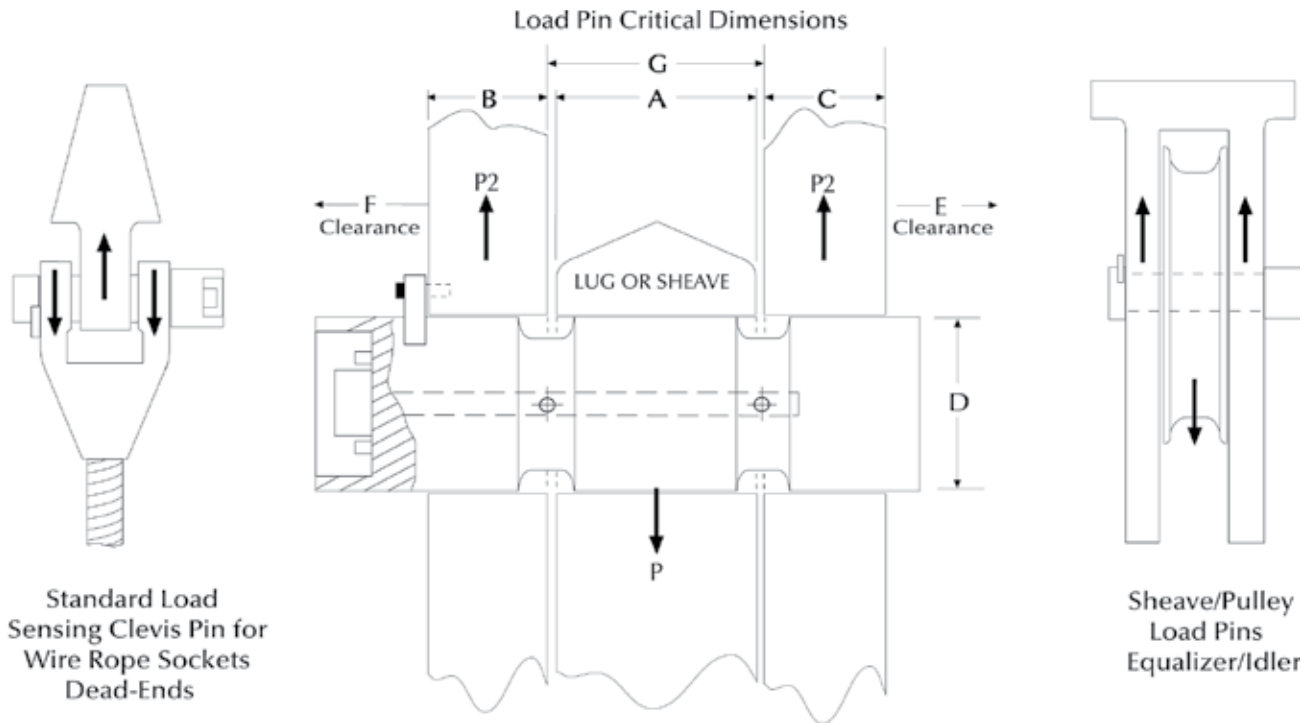

Standard Load Sensing Clevis Pin for Wire Rope Sockets Dead-Ends

Sheave/Pulley Load Pins Equalizer/Idler

Load Pin Data	
A=Width _____	Inch
B=Width _____	Inch
C=Width _____	Inch
D=Pin Diameter _____	Inch
E=Clearance _____	Inch
F=Clearance _____	Inch
G=Width _____	Inch
Lube Port <input type="checkbox"/> No <input type="checkbox"/> Yes _____	# of exits
Hoist Capacity _____	Tons
Parts of Wire Rope _____	
Sensor Capacity _____	Tons
Factor of Safety <input type="checkbox"/> 3:1 <input type="checkbox"/> 5:1 <input type="checkbox"/> 7:1 <input type="checkbox"/> 10:1	
Application _____	
Accuracy Requirement _____	
Temperature Requirement _____	
Required Output _____	
Material Testing Requirement _____	
Load Vector Orientation/Alignment <input type="checkbox"/> ← <input type="checkbox"/> → <input type="checkbox"/> ↙ <input type="checkbox"/> ↘	
Name _____	
Company _____	
Phone _____	
Note: Minimum clearance between "A" and "G" = 0.0625 inch.	

Cable Connections	
End-Mounted Cable	
End-Mounted Connector (standard)	
Side-Mounted Cable	
Side-Mounted Connector	
Recessed Connector	
Sensor's Cable Length _____	Feet
Comments _____	

MSI Shear Web Load Cell

Standard Features

- Designed to be placed above the trunnion of a load block, this integrated low-profile load cell eliminates headroom loss
- Off-axis compensation

Specifications

Accuracy (Static Load):
± (0.1%) of rated capacity

Accuracy (System):
± (0.5%) of rated capacity

Material:
4340 alloy steel, zinc plated

IP Rating:
IP67

Resistance:
700 ohms



Part Number/Price

Part #	Description	Est. Weight	Price
160651	10,000 lb/5,000 kg capacity	5 lb	\$1,905.00
163595	20,000 lb/10,000 kg capacity	10 lb	\$2,010.00
163596	40,000 lb/20,000 kg capacity	20 lb	\$2,155.00
163829	60,000 lb/30,000 kg capacity	30 lb	\$2,260.00
163597	80,000 lb/40,000 kg capacity	34 lb	\$2,365.00
163598	100,000 lb/50,000 kg capacity	38 lb	\$2,525.00
159550	120,000 lb/60,000 kg capacity	60 lb	\$2,775.00
163599	160,000 lb/80,000 kg capacity	105 lb	\$2,830.00
163600	200,000 lb/100,000 kg capacity	215 lb	\$3,085.00

Options/Accessories

Part #	Description	Price
165978	Load cell interface cable to TranSend™, 6.5 ft	\$280.00
165979	Load cell interface cable to TranSend, 10 ft	\$300.00
165980	Load cell interface cable to TranSend, 16 ft	\$315.00
165989	Load cell interface cable to TranSend, 20 ft	\$345.00
165990	Load cell interface cable to TranSend, 25 ft	\$380.00
165991	Load cell interface cable to TranSend, 32 ft	\$435.00
134498	Load cell interface cable to CellScale™, 5 ft	\$330.00
134495	Load cell interface cable to CellScale, 10 ft	\$360.00
134500	Load cell interface cable to CellScale, 15 ft	\$380.00
134499	Load cell interface cable to CellScale, 20 ft	\$405.00
134501	Load cell interface cable to CellScale, 25 ft	\$435.00

Dimensions

Part #	Capacity	A	B	C (+0.005- 0.000)	D	E	F	G	H	Required Hook Shank Diameter (+0.000,-0.005)
160651	10,000 lb	3.500	1.350	1.005	2.450	1.880	4.905	1.500	1.000	1.000
163595	20,000 lb	6.000	2.500	1.505	3.500	2.443	7.405	1.750	1.250	1.500
163596	40,000 lb	7.500	3.150	2.005	5.000	2.580	8.905	2.000	1.375	2.000
163829	60,000 lb	8.000	3.190	2.505	5.250	2.695	9.405	2.188	1.500	2.500
163597	80,000 lb	8.500	3.650	3.505	5.750	2.680	9.905	2.313	1.500	3.500
163598	100,000 lb	9.125	3.873	4.005	7.000	2.382	10.530	2.668	1.875	4.000
159550	120,000 lb	9.125	3.873	4.005	7.000	2.382	10.530	2.813	2.000	4.000
163599	160,000 lb	16.000	7.030	6.005	14.500	2.955	17.405	4.625	2.500	6.000
163600	200,000 lb	16.000	7.030	6.005	14.500	2.955	17.405	5.125	3.000	6.000

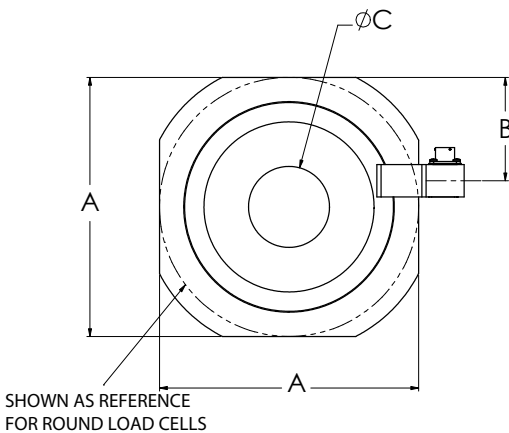
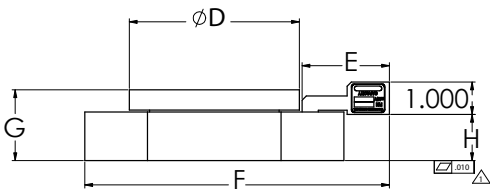

MSI-Tension Link Load Cell



Standard Features

- 4340 Steel Construction
- Mil Spec Connector
- 7:1 Safety factor

Part Number/Price

Part #	Description	Price
181907	2K 7200 Style Load Cell Only	\$885.00
181908	5K 7200 Style Load Cell Only	\$885.00
181909	10K 7200 Style Load Cell Only	\$930.00
178093	25K 7200 Style Load Cell Only	\$1,015.00
178094	50K 7200 Style Load Cell Only	\$1,585.00
181910	100K 7200 Style Load Cell Only	\$2,340.00
134505	Mating Cable Assembly, 10 ft	\$165.00

Contact factory for higher capacities

Dimensions

Capacity (lbs)	P/N	Load Cell Material	(A) Headroom Loss	(B) C-C Length	(C) Lug Thk	(D) Body Thk	(E) Body Width	(F) Body Length	Lug Hole	Crosby Shackle
2,000	181907	Aluminum	13.50	8.00	0.99	2.13	4.50	9.75	0.78	3-1/4 T 151357
5,000	181908	Aluminum	13.50	8.00	0.99	2.13	4.50	9.75	0.78	3-1/7 T 151357
10,000	181909	Aluminum	16.13	8.50	1.35	2.13	5.37	10.75	1.05	6-1/2 T 151355
25,000	178093	Steel	22.39	9.26	2.24	2.24	4.80	12.76	1.67	17 T 141992
50,000	178094	Steel	25.74	9.76	2.74	2.81	5.43	13.76	2.05	25 T 151356
100,000	181910	Steel	28.49	10.74	3.09	3.09	6.86	15.74	2.30	55 T 146336

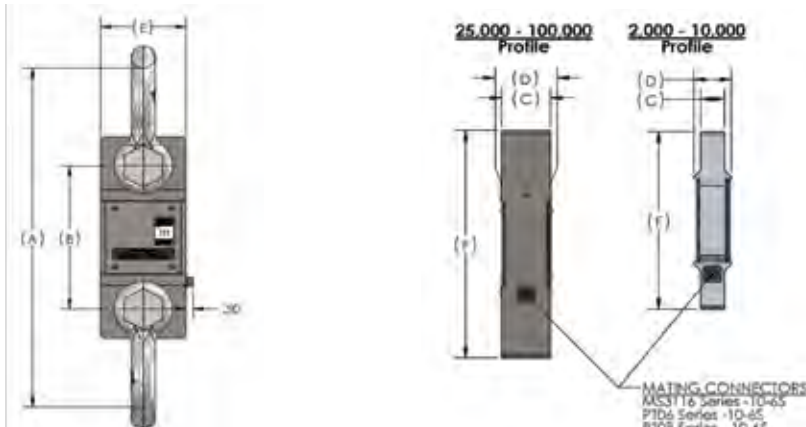

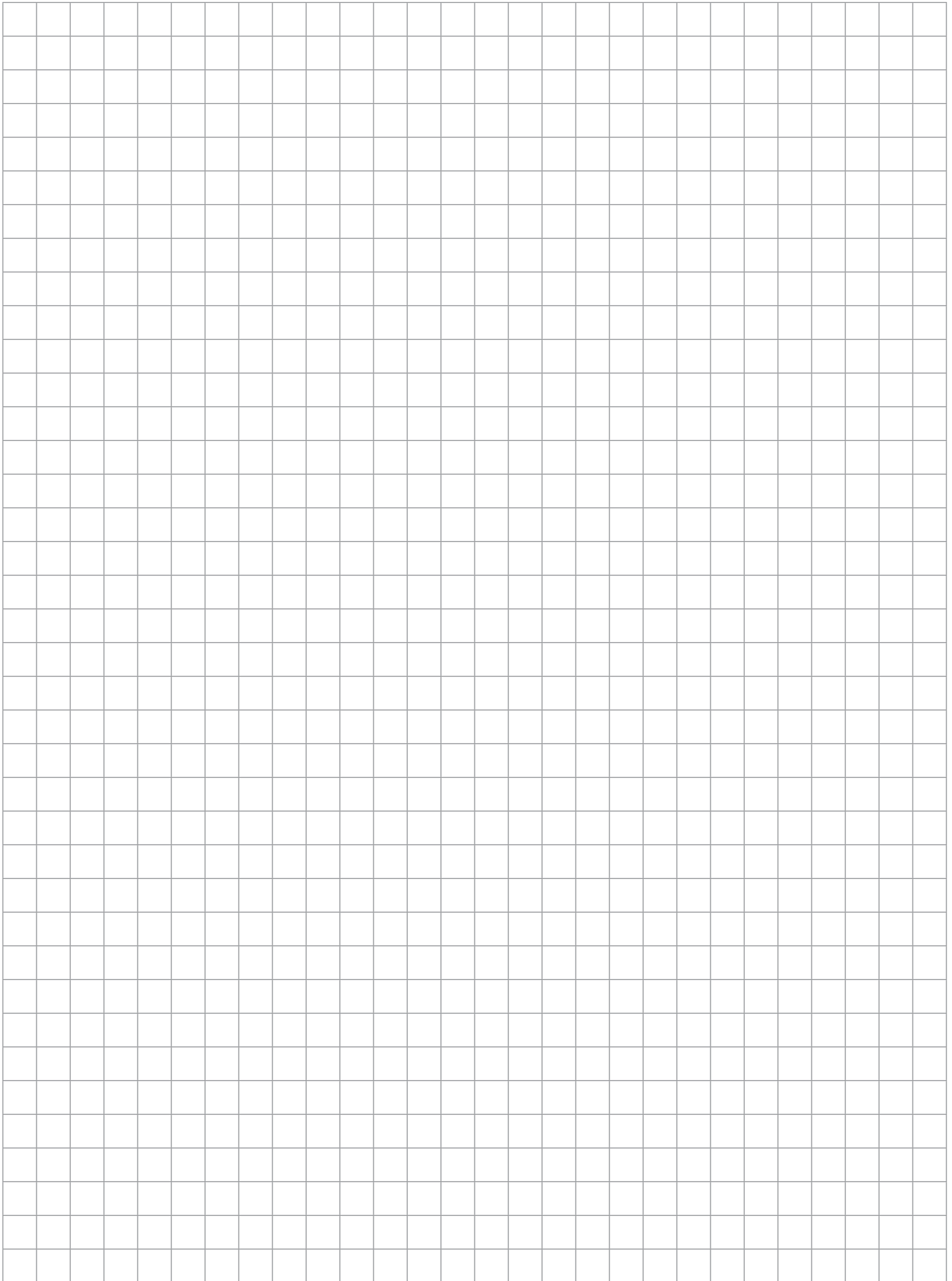

MSI-8004HD

Indicator/RF LED Remote Display



Standard Features

- IP65 rugged milled aluminum enclosure
- Backlit membrane keypad for user functioning and controls
- Tilt bracket included

Options

- Expanded relay outputs
- Battery pack for mobile operation
- Second radio module for additional network connectivity

Approvals



Measurement
Canada
Approved

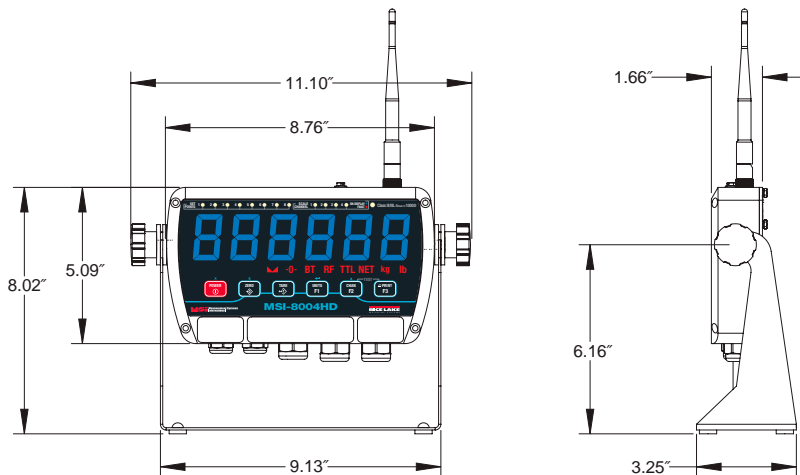

Specifications

Display

Six-digit, 1.5 in (38 mm) LED display with red/green coloring

Enclosure:

NEMA Type 4, IP65 milled anodized aluminum

Keypad:

On/Off, Zero, Tare, Print and two user-defined keys

Functions:

Peak hold, high resolution, total, view total, net/gross, units switching

Units

Pounds, kilograms, tons, metric tons, kilonewtons

Annunciators:

Stable, COZ, kg, lb, setpoint, channel LEDs,

Channels

1, 2, 3, 4, TTL

Power:

90-267 VAC, 9-36 VDC, 18-72 VDC, 120-300 VDC, 8-32V, external battery options

Temperature:

-4° F to 140° F (-20° C to 60° C) (Industrial)

RF Remote Channels:

Up to four remote sensors monitored individually, in pairs or sum all (non-A/D version only) (when used with TranSend)

Service Counters:

A/D version only

A/D Inputs:

Four independent or summing load cell inputs

Relays:

Two 5V coil, 250VAC, 5A relays

Excitation:

4.8 V current limited and over-voltage protected

Filtering:

Off, Low, Hi-1, Hi-2

RF Radio Link

2.4 GHz 802.15.4, optional second channel for Serial RF, 802.11 Wi-Fi, cellular connectivity or Bluetooth®

RF Effective Range:

Typically 300 ft (91.44 m) line of sight

Data I/O:

Two RS-232 hard wired communication ports

Approvals:

NTEP COC #17-036, Measurement Canada

Warranty:

One-year limited warranty

Part Number/Price

Indicator		
Part #	Description	Price
178265	MSI-8004HD Indicator, 4CH AC, Red/Green 85~264 VAC, 47~440 Hz, 120~370VDC	\$1,745.00
178269	MSI-8004HD Indicator, 4CH DC 8-32V, Red/Green Best for external 12V SLA Batteries	\$1,775.00
178271	MSI-8004HD Indicator, 4CH DC 9-36V Iso, Red/Green Do not use on 12V Vehicle Systems	\$1,850.00
178274	MSI-8004HD Indicator, 4CH DC 18-75V Iso, Red/Green	Consult
178278	MSI-8004HD Indicator, 4CH DC 5V, Red/Green For use with external 15W, 5V Power Supplies	Consult
183481	MSI-8004HD Indicator, 4CH 5V Red/Green with external rechargeable battery	\$1,750.00
Remote Display		
178281	MSI-8004HD Display, AC, Red/Green 85~264 VAC, 47~440 Hz, 120~370 VDC	\$1,700.00
178283	MSI-8004HD Display, DC, 8-32V, Red/Green Best for external 12 V SLA Batter	\$1,660.00
178285	MSI-8004HD Display, DC, 9-36V Iso, Red/Green Do not use on 12 V Vehicle Systems	\$1,735.00
183479	MSI-8004HD Display, 4CH 5V Red/Green with external rechargeable battery	\$1,505.00

Options

Part #	Description	Price
148624	Serial Cable, RS-232 9000 Serial Cable, DCE	\$110.00
139309	Antenna Kit, Long Range Omni-directional, 9dBi with 3m Coax Intended for omni-directional mast mounting (up to 2" Ø). Beam-width. Must be mounted vertically.	\$415.00
139310	Antenna Kit, Corner Reflector, 9 dBi with 3 m coax intended for directional wall or mast mounting (up to 2" Ø). Beam-width: 75° Elevation, 65° Azimuth	\$410.00
139311	Antenna Kit, Corner Reflector, 12 dBi with 3 m coax intended for directional wall or mast mounting (up to 2" Ø). Beam-width: 50° Elevation, 36° Azimuth	\$440.00
139312	Antenna Kit, YAGI, 15 dBi with 3 m coax highly directional wall or mast mounting (up to 2" Ø). Beam-width: 30° Elevation, 34° Azimuth	\$340.00
139313	Antenna Kit, Vehicle Mount, 5 dBi with 5 m coax omni-directional. Mounts in 3/4" Hole.	\$125.00
162178	Antenna extension kit	\$255.00
155173	Option kit, tilt stand	\$70.00
171203	Audible alarm Not compatible with battery versions 22436	\$300.00
22436	Cable, Comm DB9F 9 Pin Fem One end stripped and tinned on other end 6' Pin 2 (Brown) Pin 3 (Red) Pin 5 (Yellow) For use with MSI-8004HD serial ports to connect to: Scoreboard displays, printers, computers & other equipment that supports RS-232	\$60.00
183437	Battery, 5V Li-ion battery with USB power ports. Output 5V/3.0A per port (6.0 A max)Rate, 2A per port (4A if both ports are used)	\$190.00
184132 *	8004 option kit, Bluetooth® with SMA antenna	Consult
184131	8004 option kit, WiFi with SMA antenna	\$160.00
182224	Power Adapter, 12VDC 5VDC Dual USB Car Charger plus 3ft USB Cable	\$45.00
Relays		
172500	Expanded Relays Option Kit, four-channel, 3A, 60VPK SSR form C	\$975.00
172501	Expanded Relays Option Kit, eight-channel, 3A 60VPK, SSR form C	\$1,300.00
172493	Expanded Relays Option Kit, four-channel, 3A 60VPK, AC/DC SSR	\$720.00
172497	Expanded Relays Option Kit, eight-channel, 3A 60VPK, AC/DC SSR	\$975.00
172494	Expanded Relays Option Kit, four-channel, 0.9A 200VPK, AC/DC SSR	\$715.00
172502	Expanded Relays Option Kit, eight-channel, 0.9A 200VPK, SSR form C	\$1,140.00
172498	Expanded Relays Option Kit, eight-channel, 0.9A 200VPK, SSR	\$935.00
172492	Expanded Relays Option Kit, four-channel, 12A 5V, momentary	\$690.00
172495	Expanded Relays Option Kit, eight-channel, 12A 5V, momentary	\$715.00
172490	Expanded Relays Option Kit, four-channel, 12A 5V, latching relays	\$710.00
171676	Expanded Relays Option Kit, eight-channel, 12A 5V, latching relays	\$765.00

* Bluetooth modems only work with certain Android devices. Please contact MSI for potential applications.

MSI-8000

RF Remote Display



Standard Features

- Handheld RF remote display with six-digit 1.0 in (26.4 mm) LCD screen
- Membrane keypad for remote control functionality
- User definable function keys for added versatility
- Universal 115/230 VAC, 50/60Hz battery charger (NA plug included)
- Communicates with RF 3460, 4260, 7300, 7000 & 7001

Part Number/Price

Part #	MSI Part #	Description	Est. Weight	Price
139381	503208-0001	MSI-8000 RF remote display (requires ScaleCore™ equipped MSI-7300, MSI-4260, MSI-3460 and TranSend receivers)	5 lb	\$1,135.00

Options/Accessories

Part #	MSI Part #	Description	Est. Weight	Price
149549	503486-0001	Universal 115/230 VAC 50/60 Hz (NA plug standard) battery charger for MSI-8000 RF remote display	3 lb	\$130.00
149550	503486-0002	Universal 115/230 VAC 50/60 Hz (EC plug standard) battery charger for MSI 8000 RF remote display	1 lb	\$125.00
150964	503489-0001	DB9 female serial interface cable for MSI-8000 RF remote display	1 lb	\$160.00
151095	503506-0001	Audible alarm	0 lb	\$255.00
182223		12V car charger adapter for MSI-8000	1 lb	\$110.00

Dimensions

A	B	C	D
8.00 in (203 mm)	3.85 in (98 mm)	3.85 in (98 mm)	1.37 in (35 mm)

Specifications

Enclosure:

NEMA Type 4, IP65

Weight:

0.98 lbs (445 grams)

Keypad:

On/Off, Zero (100%), Tare, Print, and two user-defined keys for the following functions: Peak hold, high resolution, total, view total, net/gross, units switching

Display:

Six-digit 1.0 in (26.4 mm) LCD

Units Displayed:

Pounds, kilograms, tons, metric tons, kilonewtons

Annunciators:

Stable, CO2, low battery, peak, net, kg, kN, lb, M, ton, setpoint, function LEDs

Power:

Integral lithium ion battery
 Universal 115/230VAC, 50/60Hz battery charger (NA plug included)

Operating Time:

Up to 24 hours of continuous use (15 minute auto-shutoff with non-use)

Operating Temperature:

-4° F to 140° F (-20° C to 60° C)

RF Radio Link:

2.4 GHz 802.15.4
 Communicates with RF 3460, 4260, 7300, 7000 & 7001

RF Effective Range:

Typically 100 or more feet (33 m)

Connector:

Four-pin Turck connector for charging and RS-232 communication

Warranty:

One-year limited warranty

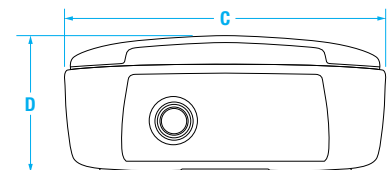
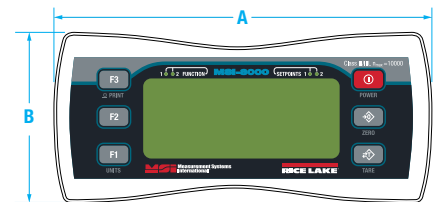

Specifications

Enclosure:

NEMA Type 4, IP68 milled anodized aluminum with O-ring gaskets

Keypad:

On/Off, Zero (100%), Tare, Print, and two user-defined keys for the following functions: peak hold, high resolution, total, view total, net/gross, units switching

Display:

Six-digit 1.0 in (26.4 mm) LCD

Units Displayed:

Pounds, kilograms, tons, metric tons, kilonewtons

Annunciators:

Stable, COZ, peak, kg, kN, lb, M, ton, setpoint, function LEDs. Channels: 1, 2, 3, 4, TTL

Power:

90-267 VAC, 9-36 VDC, 18-72 VDC, 120-300 VDC
Optional battery power module available

Operating Temperature:

-4° F to 140° F (-20° C to 60° C)

RF Remote Channels:

Up to four remote sensors, monitored individually, in pairs, or sum all (non-A/D version only)

Service Counters

A/D version only

A/D Inputs:

Two independent or summing load cell inputs

Excitation:

4.8V current limited and over-voltage protected

Filtering:

Off, Low, Hi-1, Hi-2

RF Radio Link:

2.4 GHz 802.15.4

Compatible with all ScaleCore™-based products including: MSI-7300 Dyna-Link 2, MSI-3460 Challenger 3, MSI-4260 Port-A-Weigh, MSI-7000 and MSI-7001

RF Effective Range:

Typically 100 or more feet (33 m)

Data I/O:

Dual RS-232 comm ports

Wired Ethernet:

Up to 8 configurable relay outputs

Optional Communications:

Wi-Fi

Bluetooth®

Serial RF, Frequent Hopping Spread Spectrum Optional

Warranty:

One-year limited warranty

Approvals:

NTEP COC#15-110



Shown with tilt stand.

Standard Features

- Indicator or RF remote display with six-digit 1.0 in (26.4 mm) LCD screen
- IP68 milled aluminum enclosure
- Membrane keypad for remote-control functionality
- User definable function keys for added versatility
- Compatible with all ScaleCore™-based products including: MSI-7300 Dyna-Link 2, MSI-3460 Challenger 3, MSI-4260 Port-A-Weigh, MSI-7000 and MSI-7001
- Swivel tilt stand

Optional Features

- Up to 8 configurable relay outputs
- Wi-Fi communications
- Bluetooth® communications
- 802.15.4 Serial RF
- FHSS

Approvals



MSI-8000HD

Indicator/Remote Display

CRANE SCALES

Part Number/Price

Part #	Description	Est. Weight	Price
153591	MSI 8000HD ScaleCore RF/Remote Display/85-265 VAC	5 lb (2.5 kg)	\$1,240.00
154853	MSI 8000HD ScaleCore RF/Remote Display/Internal Battery	5 lb (2.5 kg)	\$1,340.00
160476	MSI 8000HD ScaleCore RF/Remote Display/7-36 VDC	5 lb (2.5 kg)	\$1,195.00
159377	MSI 8000HD ScaleCore RF/Remote Display/18-72 VDC	5 lb (2.5 kg)	\$1,225.00
159376	MSI 8000HD ScaleCore RF/Remote Display/9-36 VDC	5 lb (2.5 kg)	\$1,225.00
158427	MSI 8000HD Meter/2 A/D Inputs/85-265 VAC (non RF)	5 lb (2.5 kg)	\$1,505.00
158428	MSI 8000HD Meter/2 A/D Inputs/Internal Battery (non RF)	5 lb (2.5 kg)	\$1,605.00
160478	MSI 8000HD Meter/2 A/D Inputs/7-36 VDC (non RF)	5 lb (2.5 kg)	\$1,340.00
159381	MSI 8000HD Meter/2 A/D Inputs/18-72 VDC (non RF)	5 lb (2.5 kg)	\$1,370.00
159380	MSI 8000HD Meter/2 A/D Inputs/9-36 VDC (non RF)	5 lb (2.5 kg)	\$1,370.00
158425	MSI-8000HD RF Meter/2 A/D Inputs/85-265 VAC	5 lb (2.5 kg)	\$1,520.00
158426	MSI-8000HD RF Meter/2 A/D Inputs/Internal Battery	5 lb (2.5 kg)	\$1,560.00
160477	MSI 8000HD RF Meter/2 A/D Inputs/7-36 VDC	5 lb (2.5 kg)	\$1,520.00
159379	MSI 8000HD RF Meter/2 A/D Inputs/18-72 VDC	5 lb (2.5 kg)	\$1,530.00
159378	MSI 8000HD RF Meter/2 A/D Inputs/9-36VDC	5 lb (2.5 kg)	\$1,530.00
176957 *	MSI 8000HD BT Meter/85-265 VAC	5 lb (2.5 kg)	Consult
176958	MSI 8000HD Wi-Fi Meter/85/265 VAC	5 lb (2.5 kg)	\$1,265.00
176959 *	MSI 8000HD BT Meter/Internal Battery	5 lb (2.5 kg)	Consult
176960	MSI 8000HD Wi-Fi Meter/Internal Battery	5 lb (2.5 kg)	\$1,370.00
176962 *	MSI 8000HD BT Meter/7-36 VDC	5 lb (2.5 kg)	Consult
176964	MSI 8000HD Wi-Fi Meter/7-36 VDC	5 lb (2.5 kg)	\$1,220.00
176965 *	MSI 8000HD BT Meter/9-36 VDC	5 lb (2.5 kg)	Consult
176966	MSI 8000HD Wi-Fi Meter/9-36 VDC	5 lb (2.5 kg)	\$1,250.00
176967 *	MSI 8000HD BT Meter/18-72 VDC	5 lb (2.5 kg)	Consult
176968	MSI 8000HD Wi-Fi Meter/18-72 VDC	5 lb (2.5 kg)	\$1,250.00

* Bluetooth modems only work with certain Android devices. Please contact MSI for potential applications.

Options/Accessories

Part #	Description	Price
155173	MSI-8000HD spare tilt stand option kit	\$70.00
155193	MSI-8000HD Ethernet TCP/IP option kit wired	\$370.00
162178	Antenna extension kit	\$255.00
148624	MSI-8000HD serial RS-232 cable	\$110.00
158779	MSI-8000HD two each coil relay option kit, 250 VAC/30 VDC 5A or 100 VDC 0.4A	\$300.00
158780	MSI-8000HD two each solid state relay option kit, 60 Vpk 2.7A	\$300.00
158781	MSI-8000HD two each solid state relay option kit, 200 Vpk 0.9A	\$300.00
149549	Universal 115/230 VAC 50/60 Hz (NA plug standard) battery charger for MSI-8000HD battery powered device	\$130.00
149550	Universal 115/230 VAC 50/60 Hz (international plugs) battery charger for MSI-8000HD battery powered device	\$125.00
176963	Reverse RS-232 cable	\$130.00
Relays		
172490	Expanded Relay Kit, Four-Channel, 12A 5V, Latching Relays	\$710.00
172492	Expanded Relay Kit, Four-Channel, 12A 5V, Momentary Relays	\$690.00
172493	Expanded Relay Kit, Four-Channel, 3A 60Vpk, AC/DC Solid State Relays	\$720.00
172494	Expanded Relay Kit, Four-Channel, 0.9A 200Vpk, AC/DC Solid State Relays	\$715.00
172495	Expanded Relay Kit, Eight-Channel, 12A 5V, Momentary Relays	\$715.00
172497	Expanded Relay Kit, Eight-Channel, 3A 60Vpk, AC/DC Solid State Relays	\$975.00
172498	Expanded Relay Kit, Eight-Channel, 0.9A 200Vpk, Solid State Relays	\$935.00
172500	Expanded Relays Option Kit, Four-Channel, 3A, 60Vpk Solid State Form C Relays	\$975.00
172501	Expanded Relays Option Kit, Eight-Channel, 3A 60Vpk, Solid State Form C Relays	\$1,300.00
172502	Expanded Relays Option Kit, Eight-Channel, 0.9A 200Vpk, Solid State Form C Relays	\$1,140.00
171676	Expanded Relays Option Kit, Eight-Channel, 12A 5V, Latching Relays	\$765.00

www.ricelake.com | Phone: 800-472-6703

RICE LAKE

Specifications

Power:

5-6 VDC, 7-36 VDC 85-265 VAC

Excitation Voltage:

Transmitter: +4.8 VDC, 16x 350Ω or 32x 700Ω load cells

Standard Antenna:

1/2 wave 2dBi, articulated

Frequency:

Direct sequence spread spectrum at 2.4 GHz, 802.15.4

Effective Range:

100 ft or more

Digital I/O:

Three coil relays available on select models and 7000HD units

Circuit Protection:

RFI, EMI, ESD protection

Serial Port:

Full duplex RS-232

Operating Temperature:

-40° F to 185° F (-40° C to 85° C)

Enclosure:

NEMA Type 4 (IP66), aluminum black powder coated (excludes wall cube model)
7000HD and 7001HD: IP68

Additional RF Options:

Wi-Fi
Bluetooth®
Cellular (consult)
802.15.4 FHSS

Warranty:

One-year limited warranty



Standard Features

- Works with any basic digital weight indicator
- Excitation to load cell(s) provided by the transmitter, not the indicator
- Each transmitter/receiver set is individually paired
- Auto-off mode - selectable for 15, 30, 45, 60 minutes or off
- Auto-sleep mode - power down during non-use, power up with weight change or key press
- Serial communication cable included with all transmitters

Additional HD Features

- IP68 milled aluminum enclosure
- 2nd radio modem available

Part Number/Price

Part #	Description	Est. Weight	Price
Transmitters			
5-6 VDC Power Input			
160330	Single-channel transmitter, no relays, RF 802.15.4, 2.4 GHz	2 lb	\$840.00
159207	Four-channel transmitter, no relays, RF 802.15.4, 2.4 GHz	2 lb	\$890.00
161949	Four-channel transmitter, includes three coil relays, RF 802.15.4, 2.4 GHz	2 lb	\$1,015.00
176644 *	Single-channel transmitter, no relays, Bluetooth	2 lb	Consult
176638 *	Four-channel transmitter, no relays, Bluetooth	2 lb	Consult
176641 *	Four-channel transmitter, includes three coil relays, Bluetooth	2 lb	Consult
176655	Single-channel transmitter, no relays, Wi-Fi	2 lb	\$885.00
176648	Four-channel transmitter, no relays, Wi-Fi	2 lb	\$935.00
176652	Four-channel transmitter, includes three coil relays, Wi-Fi	2 lb	\$1,065.00
7-36 VDC Power Input			
160329	Single-channel transmitter, no relays, RF 802.15.4, 2.4 GHz	2 lb	\$890.00
159470	Four-channel transmitter, no relays, RF 802.15.4, 2.4 GHz	2 lb	\$915.00
161951	Four-channel transmitter, includes three coil relays, RF 802.15.4, 2.4 GHz	2 lb	\$1,060.00
176645 *	Single-channel transmitter, no relays, Bluetooth	2 lb	Consult
176639 *	Four-channel transmitter, no relays, Bluetooth	2 lb	Consult
176642 *	Four-channel transmitter, includes three coil relays, Bluetooth	2 lb	Consult
176656	Single-channel transmitter, no relays, Wi-Fi	2 lb	\$935.00
176650	Four-channel transmitter, no relays, Wi-Fi	2 lb	\$960.00
176653	Four-channel transmitter, includes three coil relays, Wi-Fi	2 lb	\$1,120.00
85-265 VAC Power Input			
160328	Single-channel transmitter, no relays, RF 802.15.4, 2.4 GHz	2 lb	\$915.00
159469	Four-channel transmitter, no relays, RF 802.15.4, 2.4 GHz	2 lb	\$940.00
161950	Four-channel transmitter, includes three coil relays, RF 802.15.4, 2.4 GHz	2 lb	\$1,095.00
176643 *	Single-channel transmitter, no relays, Bluetooth	2 lb	Consult
176637 *	Four-channel transmitter, no relays, Bluetooth	2 lb	Consult
176640 *	Four-channel transmitter, includes three coil relays, Bluetooth	2 lb	Consult
176654	Single-channel transmitter, no relays, Wi-Fi	2 lb	\$960.00
176647	Four-channel transmitter, no relays, Wi-Fi	2 lb	\$990.00
176651	Four-channel transmitter, includes three coil relays, Wi-Fi	2 lb	\$1,150.00

Part Number/Price

Part #	Description	Est. Weight	Price
Receivers			
5-6 VDC Power Input			
160337	Receiver to provide a mV signal to a digital weight indicator, RF 802.15.4, 2.4 GHz	2 lb	\$890.00
160334	Receiver to provide an analog output signal: 4-20 mA, 0-20 mA, 0-5 VDC, 0-10 VDC, ±5 VDC, ±10VDC, RF 802.15.4, 2.4 GHz	2 lb	\$940.00
160016	Receiver to provide an analog output signal: 4-20 mA, 0-20 mA, 0-5 VDC, 0-10 VDC, ±5 VDC, ±10VDC, includes three coil relays, RF 802.15.4, 2.4 GHz	2 lb	\$1,065.00
7-36 VDC Power Input			
160336	Receiver to provide a mV signal to a digital weight indicator. RF 802.15.4, 2.4 GHz	2 lb	\$965.00
160333	Receiver to provide an analog output signal: 4-20 mA, 0-20 mA, 0-5 VDC, 0-10 VDC, ±5 VDC, ±10 VDC, RF 802.15.4, 2.4 GHz	2 lb	\$1,065.00
159476	Receiver to provide an analog output signal: 4-20 mA, 0-20 mA, 0-5 VDC, 0-10 VDC, ±5 VDC, ±10 VDC, includes three coil relays, RF 802.15.4, 2.4 GHz	2 lb	\$1,195.00
85-265 VAC Power Input			
160335	Receiver to provide a mV signal to a digital weight indicator, RF 802.15.4, 2.4 GHz	2 lb	\$1,010.00
160332	Receiver to provide an analog output signal: 4-20 mA, 0-20 mA, 0-5 VDC, 0-10 VDC, ±5 VDC, ±10 VDC, RF 802.15.4, 2.4 GHz	2 lb	\$1,120.00
159475	Receiver to provide an analog output signal: 4-20 mA, 0-20 mA, 0-5 VDC, 0-10 VDC, ±5 VDC, ±10 VDC, includes three coil relays, RF 802.15.4, 2.4 GHz	2 lb	\$1,295.00
7000HD:			
177942	MSI-7000HD 4CH 85-265VAC, Three Coil Relays, 802.15.4		\$1,920.00
177944	MSI-7000HD 4CH 7-36VDC, Three Coil Relays, 802.15.4		\$1,885.00
177945	MSI-7000HD 4CH 9-36VDC Iso, Three Coil Relays, 802.15.4		\$1,955.00
177950 *	MSI-7000HD 4CH 85-265VAC, Three Coil Relays, Bluetooth®		Consult
177952 *	MSI-7000HD 4CH 7-36VDC, Three Coil Relays,Bluetooth		Consult
177953 *	MSI-7000HD 4CH 9-36VDC Iso, Three Coil Relays,Bluetooth		Consult
177995	MSI-7000HD 4CH 85-265VAC, Three Coil Relays, WiFi		\$1,935.00
177997	MSI-7000HD 4CH 7-36VDC, Three Coil Relays, WiFi		\$1,895.00
177998	MSI-7000HD 4CH 9-36VDC Iso, Three Coil Relays, WiFi		\$1,980.00
7001HD			
178021	MSI-7001HD 2CH 85-265VAC, 802.15.4		\$1,150.00
178010	MSI-7001HD 2CH 5-6VDC, 802.15.4		\$1,040.00
178011	MSI-7001HD 2CH 7-36VDC, 802.15.4		\$1,115.00
178012	MSI-7001HD 2CH 9-36VDC Isolated, 802.15.4		\$1,125.00
178013 *	MSI-7001HD 2CH 85-265VAC, Bluetooth		Consult
178014 *	MSI-7001HD 2CH 5-6VDC, Bluetooth		Consult
178015 *	MSI-7001HD 2CH 7-36VDC, Bluetooth		Consult
178016 *	MSI-7001HD 2CH 9-36VDC Isolated, Bluetooth		Consult
178017	MSI-7001HD 2CH 85-265VAC, WiFi		\$1,175.00
178018	MSI-7001HD 2CH 5-6VDC, WiFi		\$1,125.00
178019	MSI-7001HD 2CH 7-36VDC, WiFi		\$1,135.00
178020	MSI-7001HD 2CH 9-36VDC Isolated, WiFi		\$1,200.00

* Bluetooth modems only work with certain Android devices. Please contact MSI for potential applications.

Options/Accessories

Part #	Description	Price
162172	Charger, TranSend™ for 6V SLA battery	\$55.00
162173	Battery, TranSend 6V SLA	\$100.00
162175	Enclosure, TranSend for 6V SLA battery	\$285.00
150964	RS-232 13 ft (4 m) serial cable with nine-pin (female) connector	\$160.00
150965	RS-232 13 ft (4 m) serial cable with nine-pin (male) connector	\$160.00
160109	AC adaptor, TranSend 6V	\$45.00
162178	Antenna extension kit for enclosures	\$255.00
139309	Antenna kit, long range Omni with 3 m coax cable	\$415.00
139310	Antenna kit, corner reflector 9 dbi with 3 m coax cable	Consult
139311	Antenna kit, corner reflector 12 dbi with 3 m coax cable	Consult
139312	Antenna kit, Yagi 15 dbi with 3 m coax	Consult
144345	30 m coaxial cable, for use with non-vehicle mount antenna kits	\$385.00
139313	Antenna kit, vehicle mount. 5 dbi with 5 m coaxial cable	Consult
162177	Cordset, TranSend, pre-wired for use with single channel transmitters or non-relay based receivers	\$105.00
162184	Load cell connector, TranSend, Field wireable, 4-6 mm straight. For use with single channel transmitters and all receivers.	\$50.00

Options/Accessories

Part #	Description	Price
162185	Load cell connector, TranSend, Field wireable, 6-8 mm straight. For use with single channel transmitters and all receivers.	\$50.00
162186	Load cell connector, TranSend, Field wireable, 4-6 mm right angle. For use with single channel transmitters and all receivers.	\$50.00
162187	Load cell connector, TranSend, Field wireable, 6-8 mm right angle. For use with single channel transmitters and all receivers.	\$50.00
143531	Power cord, 6 V SLA battery charger EU	\$20.00
143533	Power cord, 6 V SLA battery charger, Australia	\$40.00
143534	Power cord, 6 V SLA Battery charger, UK	Consult
160110	265 VAC to 6 VDC wall adapter US/UK/EU/AUS/China	\$45.00
145085	RS-232 serial cable, nine-pin unterminated	\$105.00
164865	Cable, 4 m, one-channel, mV/V output, LC input	\$130.00
165648	Cable, 5 m, one-channel, mV/V output, LC input	\$130.00
165651	Cable, 10 m, one-channel, mV/V output, LC input	\$185.00
145084	Cable, 2 m, one-channel, analog output	\$50.00
144400	Cable, 5 m, one-channel, analog output	\$80.00
168903	Cable, 10 m, one-channel, analog output	\$120.00
Consult	Straight connector, analog output, field wire able, 4-6 mM OD	Consult
Consult	Straight connector, analog output, field wire able, 6-8 mM OD	Consult
Consult	Right angle connector, analog output, field wire able, 4-6 mM OD	Consult
Consult	Right angle connector, analog output, field wire able, 6-8 mM OD	Consult
184002	7000HD Half-plate mounted, FHSS, DC (battery) powered (half plate battery power supply sold separately)	Consult
182244	GoDex portable printer (compatible with android tablet app)	Consult

MSI-9850 CellScale™ RF Digital Indicator



Standard Features

- Compatible with MSI-6260CS, MSI-9300 and MSI-9000 CellScale
- Six-digit 1.2 in (30 mm) LED display
- 1.4 in x 2.6 in (36 x 67 mm) information LCD display
- 2.4 GHz spread spectrum transceiver
- RS-232 data I/O with real-time clock
- NEMA Type 4, IP65 enclosure
- Power input 85-265VAC, 47-440 Hz / 130-300VDC; 8 ft/2.4 m power cable included (NA plug standard)

Additional Options

(Contact MSI for application consultation)

- NTEP Certified
- Long range antenna, omni-directional with 9dBi
- Wi-Fi Ethernet connectivity (802.11b)
- Hard wired Ethernet output connection
- Single and dual 4-20 mA output, provides programmable current output
- Bar code scanner
- Setpoint relays, provides up to eight setpoint relay outputs for direct interfacing to external devices
- External audible alarm (activates with setpoint control)
- Universal mounting bracket for either desktop or wall/bulkhead mount
- Optional isolated and non-isolated DC power supplies

Approvals



Specifications

Enclosure:

NEMA Type 4, IP65 milled anodized aluminum with O-ring gaskets
NEMA Type 6, IP67 with optional long-range antenna

Weight:

5.0 lb (2.8 kg)

Keypad:

33 keys—12 key alphanumeric, four cursor keys, seven control keys and 10 user programmable keys. Password protected with lock feature

Weight Display:

Six-digit, 1.2 in (30 mm) high numeric weight LED, four alphanumeric 0.5 in (13 mm) high data LED, six LED function select annunciators, ten LED annunciators, Low battery LED indicator

Information Display:

1.4 in x 2.6 in (36 x 67 mm) backlit LCD. Capable of eight lines of 21 characters each backlight selectable On, Off or Automatic

Power Input:

Internal AC/DC power supply: 85-265 VAC, 47-440 Hz/130-300 VDC. Also included: An independent 7-25 VDC power input (requires optional power/switch interface cable) 8 ft/2.4 m power cable included (NA plug standard)

Operating Temperature:

-4° F to 158° F (-20° C to 70° C)

Radio Link:

FHSS at 2.4 GHz (up to 64 network selections)

Radio Link Effective Range:

Typically 500 ft (150 m) indoor, 1,000 ft (300 m) outdoor with standard antennas. See optional antennas for longer range.

Standard Antenna:

1/2 wave 2 dBi, articulated

RFI/EMI Shielding:

Exceeds NIST HB44 and CE Standards

Connectors:

RS-232, Turck compatible Pico connector

Warranty:

One-year limited warranty

Approvals:

NTEP CC 05-077

MSI-9850 CellScale™ RF Digital Indicator

Part Number/Price

Part #	MSI Part #	Description	Capacity	Resolution	Est. Weight	Price
159625	N/A	MSI-9850 RF remote indicator AC/DC	N/A	N/A	10 lb (4.5 kg)	\$2,515.00
162035	N/A	MSI-9850 RF remote indicator AC/DC International Power	N/A	N/A	10 lb (4.5 kg)	\$2,515.00

Options/Accessories

Part #	MSI Part #	Description	Price
141558	10082	External setpoint relay output cable, 6.5 ft/2 m	\$105.00
138358	502513-0001	RS-232, 13 ft/4 m cable with DB-9 connector	\$105.00
176074		Cable, RS-232, serial output, with DB-9 connector, null modem	\$130.00
138625	502598-0001	RF remote controller (control for On/Off, Zero, Tare and other functions. 10 m operating range)	\$310.00
143466	12147	Long-range antenna, omni-directional with 9 dBi gain, includes 10 ft/3 m coaxial cable	\$425.00
Consult	Consult	9 dBi or 14 dBi gain corner reflector antenna	Consult
Consult	Consult	5 dBi gain vehicle/cab mount whip antenna, includes 17 ft/5.2 m coaxial cable	Consult
139032	502835-0001	Hard-wired Ethernet output connection, includes connector	\$355.00
139033	502835-0002	Wi-Fi Ethernet connectivity (802.11b - contact factory for assistance)	\$355.00
138615	Consult	Single 4-20 mA output. Provides programmable current output	\$535.00
138616	Consult	Dual 4-20 mA output	Consult
Consult	Consult	Bar code scanner (several options available)	Consult
Consult	Consult	Internal setpoint relays, provides up to eight setpoint relay outputs for direct interfacing to external devices	Consult
Consult	Consult	Control kit, provides remote I/O relay board for interfacing to setpoints (note: I/O modules not included)	Consult
138628	502599-0001	External audible alarm (activates with setpoint control)	\$380.00
138341	502488-0001	Universal mounting bracket for either desktop or wall / bulkhead mount (specify type)	\$135.00
138351	502499-0001	Vehicle or wall mount bracket stand	\$135.00
138631	502600-0003	Non-isolated 7-25VDC power input, includes 13 ft/4 m non-terminated DC input cable	\$135.00
138632	502600-0004	Isolated 10-36VDC power input, includes 13 ft/4 m non-terminated DC input cable	\$135.00
138633	502600-0005	Isolated 20-72VDC power input, includes 13 ft/4 m non-terminated DC input cable	\$210.00

MSI-9750A CellScale™ RF Portable Indicator



Specifications

Enclosure:

NEMA Type 3, IP54, Rugged Molded PVC, O-ring gasketed.

Dimensions:

4.6 in x 10.3 in x 2.4 in (117 x 262 x 60.5 mm)

Weight:

2.2 lb (1 kg)

Keypad:

24 keys—11 key alphanumeric, seven control keys and six user programmable keys. Password protected with lock feature

Display:

1.4 in x 2.6 in (36 mm x 67 mm) backlight LCD capable of 8 lines, 21 characters each. Backlight selectable On, Off or Automatic. Red/green LED battery charging indicator. Real time clock

Power:

Rechargeable six NiMH six cell battery pack (AC adaptor/battery charger input included)
AC adaptor/battery charger; 90-264 VAC, 47-63 Hz (NA plug standard)
Charger board: SMD NiMH fast charge (charges battery pack in two hours or less)

Operating Time:

Up to eight hours typical use. Selectable automatic shut off for battery conservation

Operating Temperature:

-4° F to 140° F (-20° C to 60° C)

Radio Link:

FHSS at 2.4 GHz (up to 64 network selections)
Compatible with MSI-6260CS, MSI-9300 and MSI-9000 CellScale

Radio Effective Range:

Typically 500 ft (150 m) indoors, 1,000 ft (300 m) outdoors with standard antennas

RFI/EMI Shielding:

Exceeds NIST HB44 and CE standards

Connectors:

Charger Input: Standard 2.5 mm coaxial cable;
RS-232 Data I/O: Standard DB-9 male

Warranty:

One-year limited

Approvals:

NTEP CC 05-077

Standard Features

- Compatible with MSI-6260CS, MSI-9300 and MSI-9000 CellScale
- 1.4 x 2.6 in (36 x 67 mm), eight line, 21 character LCD display
- 2.4 GHz spread spectrum transceiver
- Power supply: six cell NiMH battery pack
- Charger board: SMD NiMH fast charge (charges battery pack in two hours or less)
- RS-232 data I/O
- Real-time clock
- NEMA Type 3, IP54 enclosure
- AC adaptor/battery charger; 90-264 VAC, 47-63 Hz (NA plug standard)

Approvals



Part Number/Price

Part #	MSI Part #	Description	Capacity	Resolution	Est. Weight	Price
138486	502541-0001	MSI-9750 RF portable indicator	N/A	N/A	2.2 lb (1 kg)	\$1,830.00

Options/Accessories

Part #	MSI Part #	Description	Est. Weight	Price
Accessories				
143709	12431	Replacement NiMH battery pack	1 lb (0.45 kg)	\$125.00
139484	503441-0001	AC adaptor/battery charger input, 90-264 VAC, 47-63 Hz (NA plug standard)	1 lb (0.45 kg)	\$105.00
143912	12674	Battery charger, 12 VDC auto plug	1 lb (0.45 kg)	Consult
139485	503441-0002	AC adaptor/battery charger, EU plug	1 lb (0.45 kg)	Consult

Specifications

Enclosure:

NEMA Type 4, IP65 milled anodized aluminum with O-ring gaskets
NEMA Type 6, IP67 with optional long range antenna

Weight:

3.5 lb (1.6 kg)

Annunciators:

Eight LED status lamps for Power, Setpoints, Comm Port, Excitation and RF Modem

Real-Time Clock:

USA or European format programmable

Power Input:

9-30VDC (Internal 85-265VAC power supply optional)

Operating Temperature:

-40° F to 158° F (-40° C to 70° C)

Scale Inputs:

Up to two sensor inputs and six terminal connections

Excitation:

5V (+5V relative to ground)

Calibration:

Digital via input comport or RF with other CellScale weighing components. Programmable calibration settings, include: AZM, Motion, Filter, Zero, Units, Capacity and Divisions

Digital Filtering:

Two-stage programmable digital filtering

Totalization, Statistics and Product IDs:

Push-button or automatic with each ID register.
Up to 32 alphanumeric ID registers

Radio Link:

FHSS at 2.4 GHz (up to 64 network selections)

Radio Link Effective Range:

Typically 500 ft (150 m) indoor, 1,000 ft (300 m) outdoor with standard antennas. See optional antennas for longer range.

Standard Antenna:

1/2 wave 2 dBi, articulated

RFI/EMI Shielding:

Exceeds NIST HB44 and CE Standards

Data I/O:

Two programmable comports supporting RS-232 or RS-422

Push Button Inputs:

Two inputs on power connector and 1 isolated input on setpoints connector

Connectors:

12-pin MIL-C-26482 for load sensor input Turck compatible Pico for RS-232 output

Math Channels:

Eight math channels programmable for arithmetic formula processing

Internal Setpoints:

Three 60V at 350 mA internal programmable solid state relay contacts

Warranty:

One-year limited

Approvals:

NTEP CC 05-077
Measurement Canada Cert # AM-5781



Standard Features

- 2.4 GHz frequency hopping spread spectrum
- Two scale inputs and excitation with remote sensing (see accessories for mating connector)
- Power/switch cable, 13 ft (4 m) for 9-30 VDC input with two programmable switch inputs
- RS-232, RS-422 and RS-485 I/O with 13 ft (4 m) interface cable
- Three internal solid state relays for setpoint control
- Real-time clock
- NEMA Type 4, IP65 enclosure (NEMA Type 6, IP67 with long range antenna)

Approvals



Measurement
Canada
Approved

MSI-9000 CellScale™

Part Number/Price

Part #	MSI Part #	Description	Est. Weight	Price
138361	502514-0001	MSI-9000, two-channel A/D 9-30 VDC (consult factory for other configurations)	7 lb (3.5 kg)	\$2,835.00
138366		MSI-9000, AC/DC		\$3,145.00

Options/Accessories (Contact MSI for application consultation)

Part #	MSI Part #	Description	Price
Consult	Consult	NTEP Certified (contact factory for specifications)	Consult
Consult	Consult	Internal AC/DC power supply (85-265 VAC, 47-440 Hz/130-300 VDC) includes a separate, independent 9-30 VDC power input	\$305.00
137467	Consult	External 85-265 VAC, 47-440 Hz/130-300 VDC power supply for indoor and outdoor installations	\$505.00
144331	Consult	Five dBi gain vehicle/cab mount whip antenna, includes 17 ft/5.2 m coaxial cable	Consult
Consult	Consult	Single or dual 4-20 mA output. Provides programmable current output for direct connection to PLC's and other data acquisition equipment. Note: See 4-20 mA option specification sheet for available product configurations	\$465.00 \$515.00
144091	Consult	Non-terminated 4-20 mA cord set, 13 ft/4 m (longer lengths available by special order)	\$100.00
143343	Consult	Setpoints output cable, 13 ft/4 m for access to internal SS relays	Consult
Consult	Consult	Non-terminated serial cable for communication port connection, 13 ft/4 m (longer lengths available by special order)	\$100.00
Consult	Consult	Pre-wired load cell cable (various lengths for single and dual channel available)	Consult
Consult	Consult	Second A/D module (4 scale inputs - adds second 12-Pin connector)	\$615.00
Consult	Consult	CellScale Virtual Monitor (CVM) application software (enables PC to emulate scale indicator., contact factory for assistance)	Consult
Consult	Consult	Modem only equipped version (CellScale A/D removed)	\$465.00
Consult	Consult	Non-RF equipped version (CellScale RF modem removed)	\$875.00
137096	Consult	MSI-9002 breakout/summing box; 4 in (1 out or 4 in (2 out)	\$745.00
137370	Consult	MSI-9008 multiplexer; 8 in (1 out (expands single channel into 8)	\$1,120.00
Consult	Consult	Wi-Fi Ethernet Connectivity (802.11b - contact factory for assistance)	\$360.00
143297	Consult	12-Pin mating connector for single or dual scale input	\$55.00
Consult	Consult	Long range antenna, 300-500 m omni-directional with 9 dBi gain, includes 10 ft/3 m coaxial cable	Consult
143466	12147	Antenna, 9 dBi	\$425.00
144330	13205	Antenna, 9 dBi corner reflector	Consult
144329	13204	Antenna, 14 dBi corner reflector	Consult
144334	13209	Antenna cable, 3 m	Consult
143977	12750	Antenna, YAGI, 15 dBi	Consult
144332	13207	Vehicle antenna cable	Consult
148624	501705-0001	Serial cable DB9	\$110.00
150990		RF Remote option (must be ordered with PN 153549 to work properly)	\$885.00

MSI-9020 CellScale™ RF CellModem

Specifications

Enclosure:

NEMA Type 4, IP65 milled anodized aluminum with O-ring gaskets
NEMA Type 6, IP67 with optional long range antenna

Weight:

3.5 lb (1.6 kg)

Annunciators:

Three LED status lamps for power, data TX/RX and configuration

Power Input:

9-30 VDC (Internal 85-265 VAC, 47-440 Hz power supply optional)

Operating Temperature:

-4° F to 158° F (-20° C to 70° C)

Radio Link:

FHSS at 2.4 GHz (up to 64 network selections)

Radio Link Effective Range:

Typically 500 ft (150 m) indoor, 1,000 ft (300 m) outdoor with standard antennas. (See optional antennas for longer range)

Standard Antenna:

1/2 wave 2 dBi, articulated

RFI/EMI Shielding:

Exceeds NIST HB44 and CE standards

Data I/O:

One comm port with two connector interfaces for RS-232 and RS-422

Warranty:

One-year limited

Approvals:

NTEP CC 05-077



Standard Features

- Modem only component; provides serial interface with computers, printers and scoreboards to a CellScale network
- 2.4 GHz spread spectrum frequency hopping
- Power cable, 13 ft (4 m) for 9-30 VDC input
- One communication port; RS-232 or RS-422, 13 ft (4 m) interface cable
- NEMA Type 4, IP65 enclosure (NEMA Type 6, IP67 with long range antenna)

Approvals



Part Number/Price

Part #	MSI Part #	Description	Est. Weight	Price
138477	502536-0001	MSI-9020 RF CellModem	7 lb (3.5 kg)	\$2,310.00

Options/Accessories

Part #	MSI Part #	Description	Est. Weight	Price
Consult	Consult	Internal 85-265 VAC, 47-440 Hz power supply	-	\$305.00
143466	12147	Long range antenna, 300 m-500 m omni-directional with 9 dBi gain, includes 10 ft/3 m coaxial cable	1 lb (0.45 kg)	\$425.00
Consult	Consult	9 dBi or 14 dBi gain corner reflector antenna	1 lb (0.45 kg)	Consult
Consult	Consult	5 dBi gain vehicle/cab mount whip antenna, includes 17 ft/5.2 m coaxial cable	1 lb (0.45 kg)	Consult
137567	502046-0001	Non-terminated serial cable for communication port connection, 13 ft/4 m longer lengths available by special order	1 lb (0.45 kg)	\$105.00
Consult	Consult	CellScale Virtual Monitor (CVM) application software (enables PC to emulate scale indicator)	Consult	Consult

MSI Scoreboards Wireless RF

Featuring LaserLight2 Remote Displays



Specifications

Enclosure:

NEMA Type 4, IP66

Display:

Six-digit long-life LED, 4 in or 6 in

Power:

AC/DC power supply 85-265 VAC, 47-440 Hz/130-300 VDC

Radio Link:

Direct sequence spread spectrum at 2.4 GHz

Radio Link Effective Range:

Typically 300 ft (150 m) with standard antennas (see optional antennas for longer range)

Standard Antenna:

1/2 wave 2 dBi, articulated

Warranty:

One-year limited

Echo Data Output:

RS-232

Standard Features

- Swivel mounting bracket (mounts to uneven surfaces and poles)
- Integrated data repeater
- AC/DC power supply: 85-265 VAC, 47-440 Hz/130-300 VDC
- LaserLight2
- RF telemetry via 2.4 GHz modem
- Six high-intensity red digits (double-row discrete LED)
- Auto Learn mode of communication protocols
- Hold displayed weight (demand input)
- Software selectable standstill mode for no updates while in motion
- Durable weather tight IP66 enclosure
- Adjustable daylight/night intensity
- Non-glare contrast filtered lens
- Mirror (reverse image) feature
- RS-232, 20 mA and RS-485 communications
- Auto sensing 115/230 VAC power supply
- PEMs for VESA flat-wall mount or side-mounting flange
- Polyethylene breather vent inhibits internal moisture buildup
- Red, green and arrow lights in stop/go version

Part Number/Price

Part #	Description	Est. Weight	Price
178004	LaserLight2, 4 in with ScaleCore RF and swivel bracket		\$2,035.00
178006	LaserLight2, 6 in with ScaleCore RF and swivel bracket		\$2,425.00

Options/Accessories

Part #	MSI Part #	Description	Est. Weight	Price
139309	Consult	Long range antenna, 300 m-500 m omni-directional with 9 dBi gain, includes 10 ft/3 m coaxial cable	1 lb	Consult
139310	Consult	9 dBi gain corner reflector antenna	1 lb	Consult
139311	Consult	12 dBi gain corner reflector antenna	1 lb	Consult
139313	Consult	5 dBi gain vehicle/cab mount whip antenna	1 lb	Consult

MSI Scoreboards Wireless RF

Featuring LaserLight2 Remote Displays

Dimensions			
22-inch enclosure (4-inch model)			
A	22.28 in (565 mm)	C	3.28 in (85 mm)
B	10.96 in (280 mm)	D	9.80 in (250 mm)
31-inch enclosure (6-inch model)			
A	30.63 in (780 mm)	C	3.73 in (95 mm)
B	13.94 in (355 mm)	D	12.77 in (325 mm)

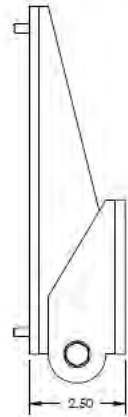
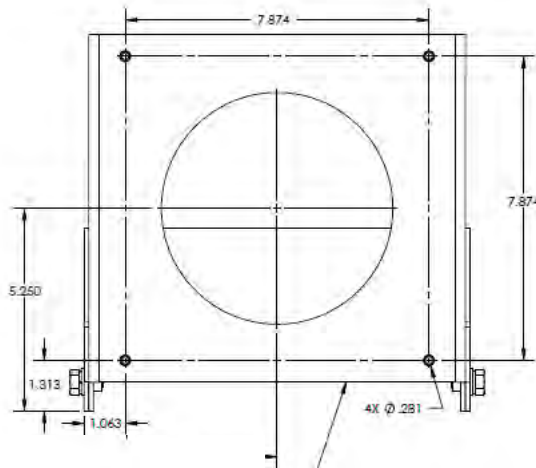
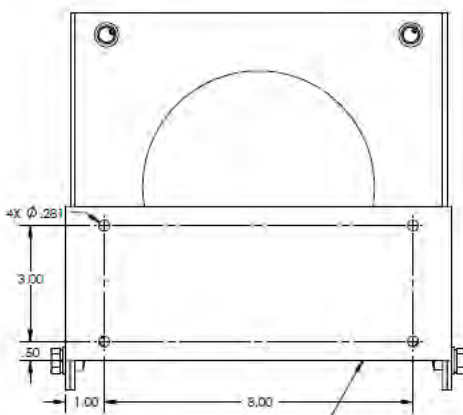
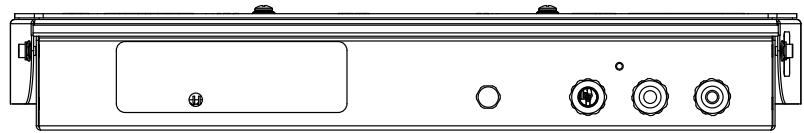
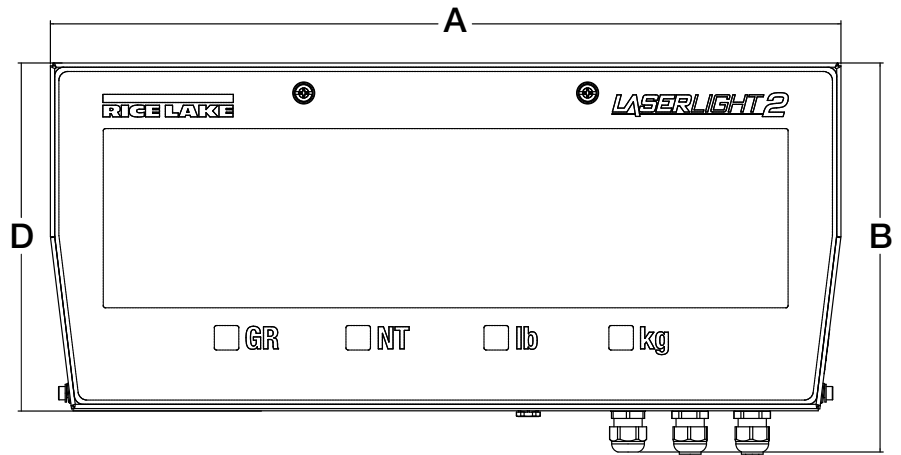
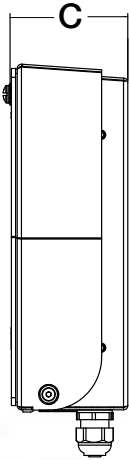

THIS BRACKET ATTACHES TO THE WALL (BOLTS NOT INCLUDED)

THIS BRACKET ATTACHES TO THE LASERLIGHT DISPLAY

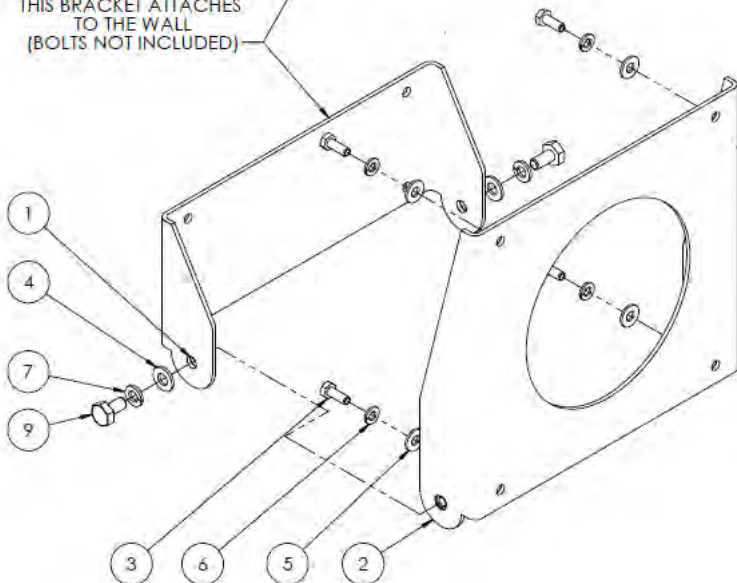

Shackle Dimensions

Part Number/Price

Part #	MSI Part #	W.L.I. Tons	Size	A	B	C	D	E	F	H	L	N	P	Weight	Price
151357	10541	3 1/4	0.63	1.06	.75	2.38	0.63	1.69	1.56	4.22	2.94	0.69	N/A	1.58	Consult
151355	10538	6 1/2	0.88	1.44	1.00	3.31	0.88	2.28	2.13	5.75	4.03	0.97	5.00	3.95	Consult
141992	10539	17	1.50	2.38	1.63	5.75	1.50	3.88	3.63	9.88	6.88	1.62	8.25	19.50	Consult
151356	10540	25	1.75	2.88	2.00	7.00	1.75	5.00	4.32	11.88	8.50	2.12	9.59	31.30	Consult
146334	23650-0030	30	1.50	2.38	1.63	5.75	1.50	3.88	3.63	9.88	6.88	1.62	8.25	20.80	Consult
146335	23650-0040	40	1.75	2.88	2.00	7.00	1.75	5.00	4.32	11.88	8.50	2.12	9.59	33.91	Consult
146336	23650-0050	55	2.00	3.25	2.25	7.75	2.00	5.75	5.00	13.38	9.75	2.00	11.00	51.75	Consult
151359	N/A	85	2.5	4.12	2.75	10.50	2.72	7.25	5.69	17.84	12.87	3.12	13.58	96.00	Consult
151360	23650-0110	120	3.00	5.00	3.25	13.00	3.00	7.88	6.50	21.50	14.50	3.63	16.50	178.00	Consult
83455	N/A	120	3	5.00	3.25	13.00	3.11	7.88	6.50	21.50	14.36	3.63	15.13	178.00	Consult
151361	23650-0175	175	4.00	5.50	4.25	14.50	4.00	10.00	9.00	25.69	18.38	4.56	19.75	338.00	Consult
151358		250	4	8.50	5.00	20.00	4.50	13.00	12.00	35.00	24.50	6.50	22.68	600.00	Consult
Oversized Shackles															
148497	501386-0100	40	1.75	2.88	2.00	10.00	2.25	6.00	4.32	15.35	10.50	2.25	9.00	45.00	Consult
148393	501082-0100	40	2.25	2.88	2.00	12.50	2.25	8.00	4.32	17.85	12.50	2.25	10.00	90.00	Consult
148394	501083-0100	50	2.00	3.25	2.25	12.25	2.50	8.00	5.00	18.50	13.00	2.50	11.00	72.00	Consult
Shims															
146534	30013-0112	(For use with 50,000 ton/70,000 ton systems)													Consult

