

Truck / Rail / Livestock / Axle Scales

TABLE OF CONTENTS

SURVIVOR® TRUCK, RAIL AND LIVESTOCK SCALES	970
RAILBOSS®	971
<i>Full Draft or Double Draft</i>	
ROUGHDECK® SLV	973
<i>Single Animal Livestock Scale</i>	
FARM BARS	975
ROUGHDECK® AX	977
<i>Tandem Axle Scale</i>	
AX3040	979
<i>Tandem Axle Scale</i>	
ROUGHDECK® AX-1	981
<i>Axle Scale</i>	
LOAD RANGER	984
<i>Wireless Wheel Pad Scale</i>	

ESPAÑOL | Visit ricelake.com/spanish
to see all Rice Lake materials
available in Spanish

*The following product names, logos, brands and other trademarks featured
or referred to within this publication are the property of their respective trademark holders.*

SURVIVOR® Truck, Rail and Livestock Scales

For more information on Rice Lake's full line of SURVIVOR® truck, rail and livestock scales, please visit our website at www.ricelake.com or call 800-472-6703 and ask to speak with a heavy capacity team member.



Truck Scales:

www.ricelake.com/truckscales

SURVIVOR® OTR

Heavy-duty, top access, concrete or steel deck scales

SURVIVOR® OTR-LP

Heavy-duty, steel deck, low profile scale for existing foundations

SURVIVOR® OTR-XV

Extreme duty, top access, concrete or steel deck scales

SURVIVOR® ATV

Heavy or extreme duty, top access portable steel deck scales

SURVIVOR® SR

Heavy-duty, low profile, concrete or steel deck siderail scales

SURVIVOR® PT

Heavy-duty, pit-type, concrete or steel deck scales

SURVIVOR® Multi-Platform

SURVIVOR® ATV-M

Portable, self-contained levertronic, steel deck scales

SURVIVOR® PT-M

Pit-type, levertronic, concrete deck scales

Rail Scales:

www.ricelake.com/railscales

SURVIVOR® RT

Pit-type, rail/truck combination scales

SURVIVOR® PL

Low profile, pitless scales

RailBoss®

Full- or double-draft rail scales

Livestock Scales:

www.ricelake.com/livestockscales

SURVIVOR® AG Series

Livestock/agriculture utility scale

SURVIVOR® LV Series

Livestock ring scale

SAS

Single animal scale

MAS-M, MAS-P, MAS-LC, MAS-LM

Multiple animal livestock scales

RoughDeck SLV

Single animal scale

Farm Bars

Universal load bars

Specifications

Load Cells:

40,000 lb

Accuracy:

≤ 0.25% error typical, interchangeable with other gauged rail products

Full Scale Capacity:

320,000 lb

Axle Capacity:

80,000 lb

Warranty:

Two-year limited warranty



* Non Legal for Trade

RailBoss - Standard Features

- 80,000 lb axle capacity
- 320,000 lb full scale capacity
- 40,000 lb rail section capacity
- 90 RA, 115 RE or 132 RE rail sections
- 5 ft 10 in rail sections, pre-drilled for joint bars
- Quick-disconnect cable connection with MS style connector

Full Draft Package Includes:

- (8) 5 ft 10 in rail sections
- 30 ft of connecting cable per rail section
- Pre-drilled joint bars with connection hardware
- (2) Rice Lake junction boxes with transient protection
- 30 ft of homerun cable

Double Draft Package Includes:

- (4) 5 ft 10 in rail sections
- 30 ft of connecting cable per rail section
- Pre-drilled joint bars with connection hardware
- (1) Rice Lake junction box with transient protection
- 30 ft of homerun cable

Optional Features:

- Custom rail sizes are available
- 1280 Enterprise Series™ indicator with RailBoss software for full-draft or double-draft applications*
- 920i® indicator with RailBoss software for full-draft or double-draft applications*
- Custom cable lengths

* Non Legal for Trade



Railboss Calibration Tool

Calibration Unit - Standard Features

- Battery powered IQ plus® 590 indicator
- Attachment hardware for 90RA, 115RE and 132RE rails

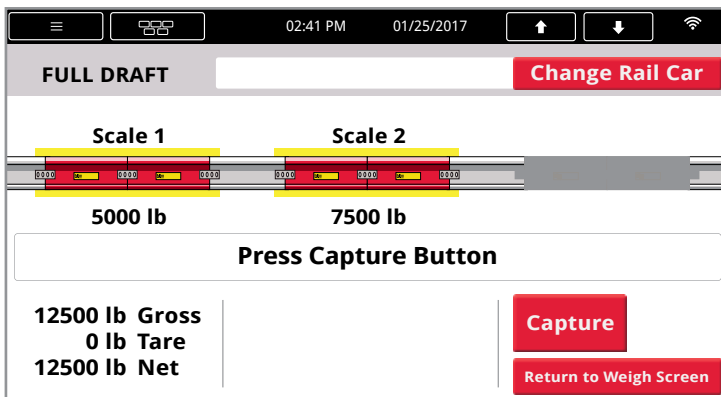

Full-draft RailBoss software display with a 1280 indicator

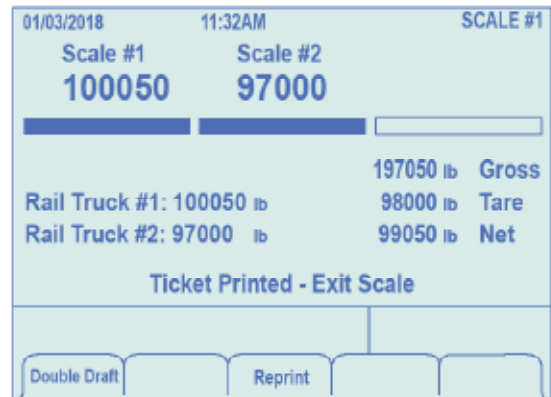

Double-draft RailBoss software display with a 920i indicator

Part Number/Price

Part Number	Description	Est. Weight	Price
Kits			
164748	RailBoss assembly kit, full draft, 90 RA rail V2	2,280 lb	\$37,100.00
164749	RailBoss assembly kit, double draft, 90 RA rail V2	1,150 lb	\$18,500.00
162515	RailBoss assembly kit, full draft, 115RE rail V2	2,550 lb	\$37,300.00
162516	RailBoss assembly kit, double draft, 115RE rail V2	1,275 lb	\$18,600.00
164752	RailBoss assembly kit, full draft, 132RE rail V2	2,800 lb	\$37,700.00
164753	RailBoss assembly kit, double draft, 132RE rail V2	1,400 lb	\$18,900.00
Single Rail Gauge Assemblies			
164750	RailBoss 90 lb gauge assembly V2 (does not include cable)	290 lb	\$4,825.00
162517	RailBoss 115 lb gauge assembly V2 (does not include cable)	320 lb	\$4,825.00
164754	RailBoss 132 lb gauge assembly V2 (does not include cable)	350 lb	\$4,825.00
Instrumentation			
119073	Single-channel 920i® indicator double draft with RailBoss software	10 lb	\$2,550.00
119072	Dual-channel 920i® indicator full draft with RailBoss software	10 lb	\$2,650.00
126304	Three-channel 920i® indicator full draft with RailBoss software	10 lb	\$2,725.00
190949	Single-channel 1280 indicator double draft with RailBoss software	11 lb	\$3,350.00
190951	Dual-channel 1280 indicator full draft with RailBoss software	11 lb	\$3,500.00
190952	Three-channel 1280 indicator full draft with RailBoss software	11 lb	\$3,850.00
Hardware			
126391	90 RA 24 in short toe joint bar set, 4 sets required (2 bars with bolts and nuts)	40 lb	\$1,225.00
126389	115 RE 24 in short toe joint bar set, 4 sets required (2 bars with bolts and nuts)	50 lb	\$950.00
126390	132 RE 24 in short toe joint bar set, 4 sets required (2 bars with bolts and nuts)	60 lb	\$1,095.00
126111	90 RA isolation joint bar set, 4 sets required (2 bars with bolts and nuts)	40 lb	\$995.00
112702	115 RE isolation joint bar set, 4 sets required (2 bars with bolts and nuts)	50 lb	\$995.00
119771	132 RE isolation joint bar set, 4 sets required (2 bars with bolts and nuts)	60 lb	\$995.00
163004	30 ft interface cable	-	\$460.00
164873	60 ft interface cable	-	\$625.00
164874	100 ft interface cable	-	\$825.00
188909	Adaptor cable from AWT Weighline to Rice Lake RailBoss	-	\$495.00
Calibration Equipment			
115564	RailBoss calibration/test unit	300 lb	\$9,500.00
119068	Railboss calibration/test until rental	300 lb	Consult

NOTE: Instrumentation with RailBoss software must be ordered separately and is not included with the RailBoss assembly kit

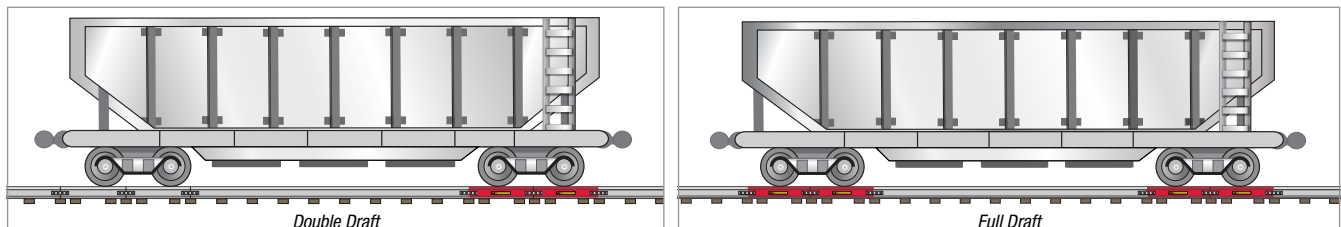
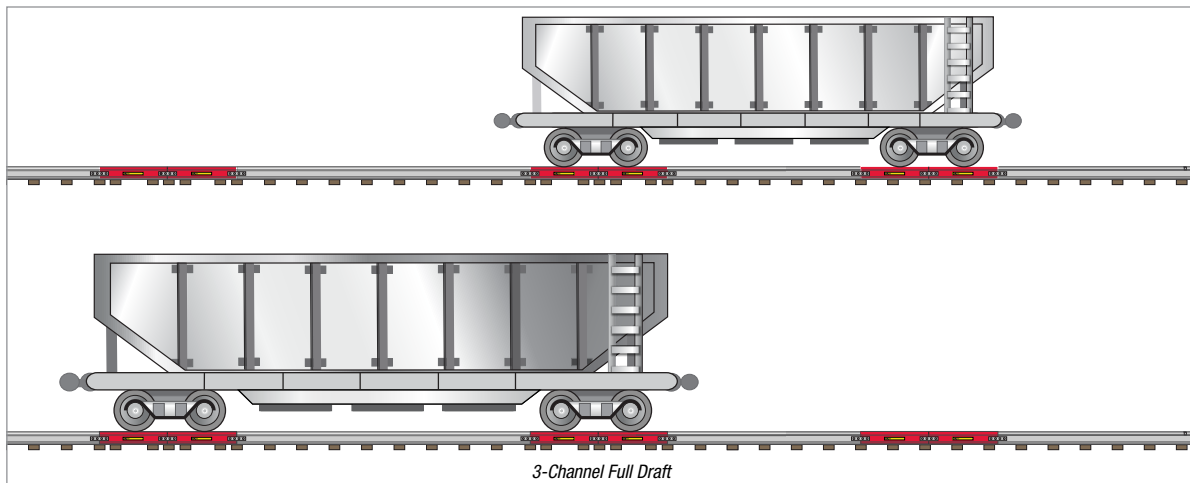

Specifications

End Load Capacity:

125% full scale

Outside Dimension:

(L x W) 8 ft x 3 ft

(L x W) 8 ft x 4 ft

Cable Length:

20 ft (6 m)

Capacity: not to exceed 4,000 x 1 lb (32 sq ft.)

8 ft x 3 ft: 4,000 lb

8 ft x 4 ft: 4,000 lb

Warranty:

Two-year limited warranty (scale only)

Approvals:

NTEP CC 92-001 Class III 4,000d



Shown with racks and optional sliding gate

Standard Features

- Swing gate
- Mild steel construction
- Rugged diamond safety treadplate deck
- Rigid structural steel channel frame
- NEMA 4X stainless steel side-access junction box without quick connector
- Signal trim summing board
- Four adjustable stainless steel SUREFOOT™ support feet
- 20 feet SURVIVOR® EL147HE hostile environment load cell cable
- Four alloy steel load cells

APPROVALS



Part Number/Price

Part #	Outside Dimensions	Capacity	Est. Weight	Price
103617	8 ft x 3 ft	4,000 lb, 20 ft without Quick Connect, modified to fit gate and rack	565 lb	\$2,800.00
78452	8 ft x 3 ft	4,000 lb, 20 ft without Quick Connect	565 lb	\$2,800.00
103619	8 ft x 4 ft	4,000 lb, 20 ft without Quick Connect, modified to fit gate and rack	750 lb	\$2,900.00
78453	8 ft x 4 ft	4,000 lb, 20 ft without Quick Connect	750 lb	\$2,900.00
RoughDeck SLV 4,000 lb Bundle Package (Ships Assembled)				
124192	8 ft x 3 ft	Includes: scale, gate and rack, kick plates, 482 digital indicator, factory calibration	1,200 lb	\$5,100.00
124193	8 ft x 4 ft	Includes: scale, gate and rack, kick plates, 482 digital indicator, factory calibration	1,500 lb	\$5,500.00

Options/Accessories

Part #	Description	Price
N/A	Smooth deck instead of diamond safety tread plate	N/C
N/A	Stainless steel load cells (RL35023S) and stainless steel junction box	\$705.00
N/A	Stainless steel welded-seal IP67 load cells (RL35082) and stainless steel junction box	\$1,170.00
N/A	Angle iron bolted to scale for wood deck provisions (wood to be supplied by customer)	\$200.00
N/A	Rubber mat	Consult
N/A	Slide gate	Consult
Consult	Chutes for use with 8 ft x 4 ft scale only	Consult
18777	Floor anchor plates, mild steel (set of 2)	\$35.00
18778	Floor anchor plates, stainless steel (set of 2)	\$38.00

RoughDeck® SLV

Single Animal Livestock Scale

TRUCK / RAIL / LIVESTOCK / AXLE SCALES

www.ricelake.com | Phone: 800-472-6703

RICE LAKE

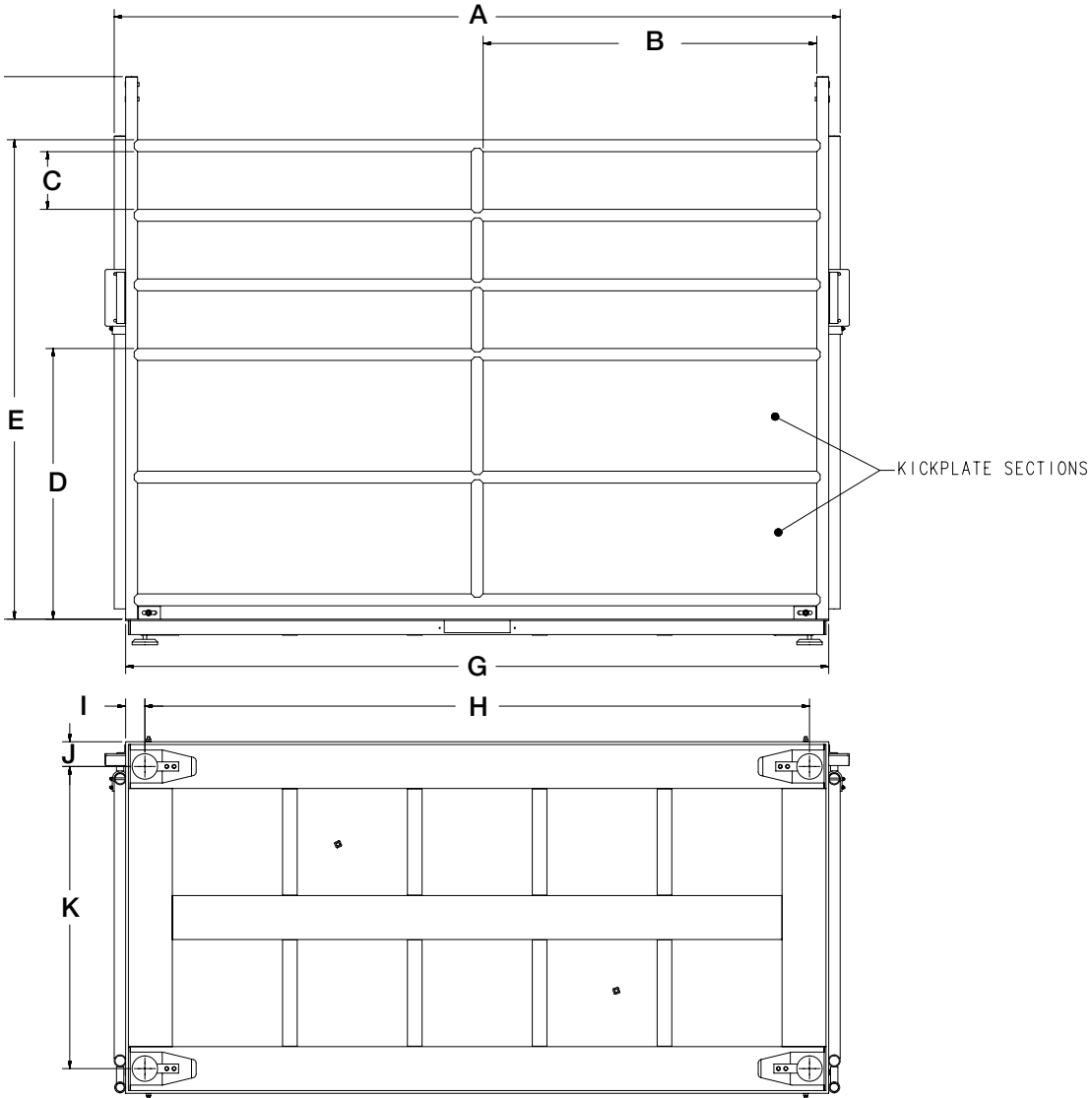

Dimensions			
3 ft x 8 ft			
A	99.12 in	I	2.625
B	45.56	J	3.375
C	7.88	K	29.25
D	36.95	L	36
E	65.45	M	32.75
F	74.00	N	3.50
G	95.00	O	77.58
H	90.75		
4 ft x 8 ft			
A	99.12 in	I	2.625
B	45.56	J	3.375
C	7.88	K	41.250
D	36.95	L	48
E	65.45	M	44.75
F	74.00	N	3.50
G	95.00	O	77.58
H	90.75		

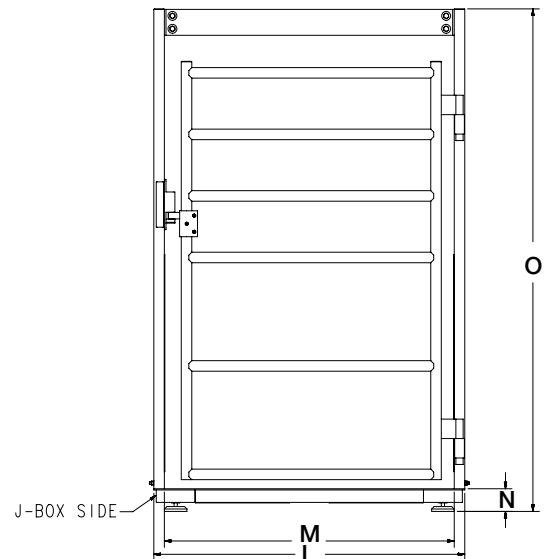

Specifications

Safe Overload:

150%

Full Scale Output (FS):

3mv/V nominal**

Maximum Excitation:

15 VDC

Non Linearity:

0.02% FS

Hysteresis:

0.02% FS

Thermal Sensitivity Shift:

0.0008% of reading/° F

Thermal Zero Shift:

0.0015% FS/° F

Side Discrimination:

1000:1

Bridge Resistance:

350 ohms

Temperature Range:

-40 to 111°F (-40 to 44° C)

Cable Configuration:

8 ft between bars and 12 ft for the indicator

Warranty:

Two-year limited warranty

*** Output is standardized for each model of load bar, consult factory for details*



Standard Features

- Three feet ArmorGuard cable included
- Kit includes 482 digital weight indicator
- Factory calibrated

Farm Bars

TRUCK / RAIL / LIVESTOCK / AXLE SCALES

www.ricelake.com | Phone: 800-472-6703

RICE LAKE

Part Number/Price

Part #	Size L x W x H	Description	Est. Weight	Price
With Instrumentation				
2,500 lb Capacity				
127519	22 x 2 x 4 in	2,500 lb 22 – Farm Bar Kit, 22 in with 482, 2,500 capacity, square pads	98 lb	\$2,195.00
5,000 lb Capacity				
130259	26 x 2 x 4 in	5,000 lb 26 – Farm Bar Kit, 26 in with 482, 5,000 capacity, square pads	117 lb	\$2,495.00
127761	33 x 2 x 4 in	5,000 lb 33 – Farm Bar Kit, 33 in with 482, 5,000 capacity, square pads	123 lb	\$2,495.00
130264	36 x 2 x 4 in	5,000 lb 36 – Farm Bar Kit, 36 in with 482, 5,000 capacity, square pads	128 lb	\$2,495.00
128678	40 x 2 x 4 in	5,000 lb 40 – Farm Bar Kit, 40 in with 482, 5,000 capacity, square pads	134 lb	\$2,495.00
128679	44 x 2 x 4 in	5,000 lb 44 – Farm Bar Kit, 44 in with 482, 5,000 capacity, square pads	140 lb	\$2,495.00
130269	48 x 2 x 4 in	5,000 lb 48 – Farm Bar Kit, 48 in with 482, 5,000 capacity, square pads	146 lb	\$2,495.00
10,000 lb Capacity				
185436	32 x 2 x 4 in	10,000 lb 32 – Farm Bar Kit, 32 in with 482, 10,000 capacity, square pads	152 lb	\$2,695.00
127498	36 x 2 x 4 in	10,000 lb 36 – Farm Bar Kit, 36 in with 482, 10,000 capacity, square pads	152 lb	\$2,695.00
127502	48 x 2 x 4 in	10,000 lb 48 – Farm Bar Kit, 48 in with 482, 10,000 capacity, square pads	175 lb	\$2,695.00
127504	60 x 2 x 4 in	10,000 lb 60 – Farm Bar Kit, 60 in with 482, 10,000 capacity, square pads	210 lb	\$2,695.00
127506	72 x 2 x 4 in	10,000 lb 72 – Farm Bar Kit, 72 in with 482, 10,000 capacity, square pads	230 lb	\$2,695.00
Without Instrumentation				
2,500 lb Capacity				
152016	22 x 2 x 4 in	2,500 lb 22 – Farm Bar set, with square pads	92 lb	\$1,795.00
5,000 lb Capacity				
152018	26 x 2 x 4 in	5,000 lb 26 – Farm Bar set, with square pads	111 lb	\$2,095.00
152019	33 x 2 x 4 in	5,000 lb 33 – Farm Bar set, with square pads	117 lb	\$2,095.00
152020	36 x 2 x 4 in	5,000 lb 36 – Farm Bar set, with square pads	122 lb	\$2,095.00
152021	40 x 2 x 4 in	5,000 lb 40 – Farm Bar set, with square pads	128 lb	\$2,095.00
152022	44 x 2 x 4 in	5,000 lb 44 – Farm Bar set, with square pads	134 lb	\$2,095.00
152023	48 x 2 x 4 in	5,000 lb 48 – Farm Bar set, with square pads	140 lb	\$2,095.00
10,000 lb Capacity				
185437	32 x 2 x 4 in	10,000 lb 32 – Farm Bar set, with square pads	146 lb	\$2,395.00
152024	36 x 2 x 4 in	10,000 lb 36 – Farm Bar set, with square pads	146 lb	\$2,395.00
152025	48 x 2 x 4 in	10,000 lb 48 – Farm Bar set, with square pads	169 lb	\$2,395.00
152026	60 x 2 x 4 in	10,000 lb 60 – Farm Bar set, with square pads	204 lb	\$2,395.00
152027	72 x 2 x 4 in	10,000 lb 72 – Farm Bar set, with square pads	224 lb	\$2,395.00

Options/Accessories

Part #	Description	Price
127776	Cable with rubber hose shield, 8 ft long	\$35.00
159788	Extension cable, farm bar, 10 ft long	\$195.00
127556	Four-pin male connector 12 ft for indicator	\$95.00
127777	Inline with 3 ft stainless steel flex conduit and dust cap	\$95.00
164582	482 Indicator	\$925.00
23113	Printer TM-U295 (Non-Legal for Trade)	\$615.00
71630	Scale tickets, 500/pack	\$50.00

Specifications

End Loading Capacity:

133% full scale at 30,000 lb

Warranty:

Weldment five years, load cells two years, all other components one-year limited warranty



Standard Features

- System includes two platforms with anchor brackets and four on/off ramps with anchor tabs (anchor bolts not included)

Scale

- (W x L x H): 32 x 84 x 6 in
- Axle capacity - tandem platforms - 60,000 lb (two scales 30,000 lb each)
- Includes (2) 3/4-10 NC eye bolts
- Contains four environmentally sealed, IP67 20,000 lb single-ended shear beam load cells per platform
- Treaded top plate with side access junction box
- JB4SS TuffSeal® signal trim junction box
- Top access foot adjustment holes
- Carbon steel captured ball feet
- 20 ft SURVIVOR® EL147HE cable
- Non-Legal for Trade

Ramps

- (W x L x H) 32 x 60 x 6 in
- Treaded top plate

Part Number/Price

Part #	Description	Dimensions	Est. Weight	Price
107637	60,000 lb (30,000 lb each)	32 x 205.5 x 6 in	3,600 lb	\$13,695.00
RoughDeck AX Bundle Package				
153058	60,000 lb (30,000 lb each) includes 920i Universal 115 VAC with short axle program, 4 in LaserLight 2 with Stop/Go light, TM-U295 and RS-232 cable	32 x 205.5 x 6 in	3,700 lb	\$17,775.00

RoughDeck® AX

Axle Scale

TRUCK / RAIL / LIVESTOCK / AXLE SCALES

Dimensions			
A	84.0 in (213.36 cm)	E	6.0 in (15.24 cm)
B	32.0 in (81.28 cm)	F	1.0 in (2.54 cm)
C	205.5 in (521.97 cm)	G	0.75 in (1.91 cm)
D	38.75 in (98.42 cm)		

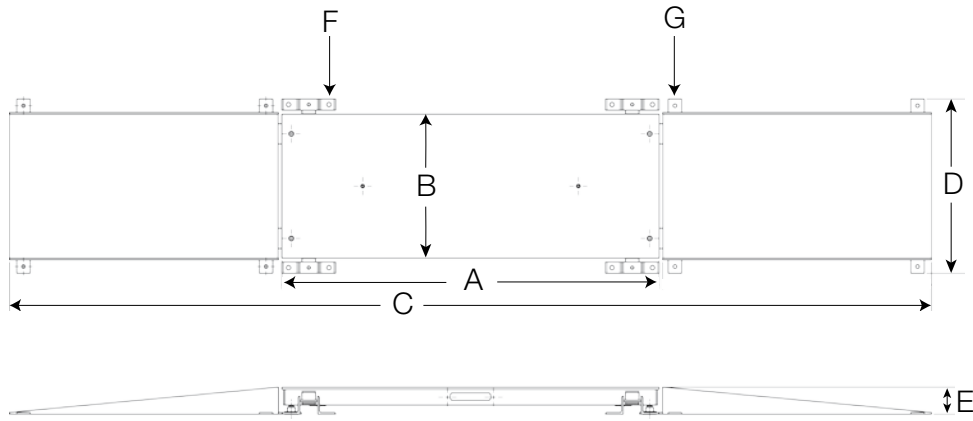

www.ricelake.com | Phone: 800-472-6703

RICE LAKE

978

Specifications

Construction:

Steel or aluminum

Accuracy:

±3%

End Loading Capacity:

100% full scale at 30,000 lb

75% full scale at 40,000 lb

Warranty:

One-year limited warranty



Standard Features

- System includes two platforms with anchor brackets and four on/off ramps with anchor tabs (anchor bolts not included)
- Sizes: 7, 12 and 14 ft lengths
- Construction: Steel or aluminum
- Axle capacity - tandem platforms - 60,000 lb or 80,000 lb (30,000 lb or 40,000 lb each)
- Includes (4) 5/8-11 NC eye bolts
- JB4SS TuffSeal® signal trim junction box
- Treaded top plate with four lifting eyes
- 10 ft EL146HE Interconnect cable with MS-type connectors to go between weigh pads
- Contains two load cells per platform
- 50 ft EL147HE cable to connect weigh pad to indicator
- Non-Legal for Trade

Ramps

- (W x L): 32 x 25.25 in
- Steel or aluminum

Part Number/Price

Part #	Description	Dimensions	Est. Weight	Price
Steel Construction - Painted Black				
112330	60,000 lb (30,000 lb each)	2.5 ft x 7 ft x 5.63 in	2,500 lb	\$12,375.00
111748	80,000 lb (40,000 lb each)	2.5 ft x 12 ft x 5.63 in	4,400 lb	\$14,650.00
112328	80,000 lb (40,000 lb each)	2.5 ft x 14 ft x 5.75 in	5,200 lb	\$19,435.00
Steel Construction - AX3040 Bundle Package				
153059	60,000 lb (30,000 lb each) includes 920i Universal 115 VAC with short axle program, SURVIVOR® 4 in LaserLight with Stop/Go light, TM U295 and RS-232 cable	2.5 ft x 7 ft x 5.63 in	2,600 lb	\$16,455.00
153060	80,000 lb (40,000 lb each) includes 920i Universal 115 VAC with short axle program, SURVIVOR® 4 in LaserLight with Stop/Go light, TM U295 and RS-232 cable	2.5 ft x 12 ft x 5.63 in	4,500 lb	\$18,730.00
153061	80,000 lb (40,000 lb each) includes 920i Universal 115 VAC with short axle program, SURVIVOR® 4 in LaserLight with Stop/Go light, TM U295 and RS-232 cable	2.5 ft x 14 ft x 5.75 in	5,300 lb	\$23,515.00
Aluminum Construction - Glass Beaded				
112329	60,000 lb (30,000 lb each)	2.5 ft x 7 ft x 5.63 in	1,250 lb	\$15,895.00
Aluminum Construction - AX3040 Bundle Package				
153062	60,000 lb (30,000 lb each) includes 920i Universal 115 VAC with short axle program, 4 in LaserLight 2 with Stop/Go light, TM U295 and RS-232 cable	2.5 ft x 7 ft x 5.63 in	1,350 lb	\$19,075.00

AX3040

Axle Scale

TRUCK / RAIL / LIVESTOCK / AXLE SCALES

Dimensions			
7 foot steel			
A	83.60 in (2,123.44 mm)	E	31.00 in (787.4 mm)
B	90.90 in (2,308.86 mm)	F	32.00 in (812.8 mm)
C	141.25 in (3,587.75 mm)	G	5.63 in (143.0 mm)
D	30.00 in (762.00 mm)		
12 foot steel			
A	143.60 in (3,647.44 mm)	E	31.00 in (787.4 mm)
B	150.90 in (3,832.86 mm)	F	32.00 in (812.8 mm)
C	201.2 in (5,111.75 mm)	G	5.63 in (143.0 mm)
D	30.00 in (762.00 mm)		
14 foot steel			
A	167.60 in (4,257.04 mm)	E	31.00 in (787.4 mm)
B	174.90 in (4,442.46 mm)	F	32.00 in (812.8 mm)
C	225.25 in (5,721.35 mm)	G	5.75 in (146.05 mm)
D	30.00 in (762.00 mm)		
7 foot aluminum			
A	83.60 in (2,123.44 mm)	E	31.00 in (787.4 mm)
B	90.90 in (2,308.86 mm)	F	32.00 in (812.8 mm)
C	141.25 in (3,587.75 mm)	G	5.63 in (143.0 mm)
D	30.00 in (762.00 mm)		

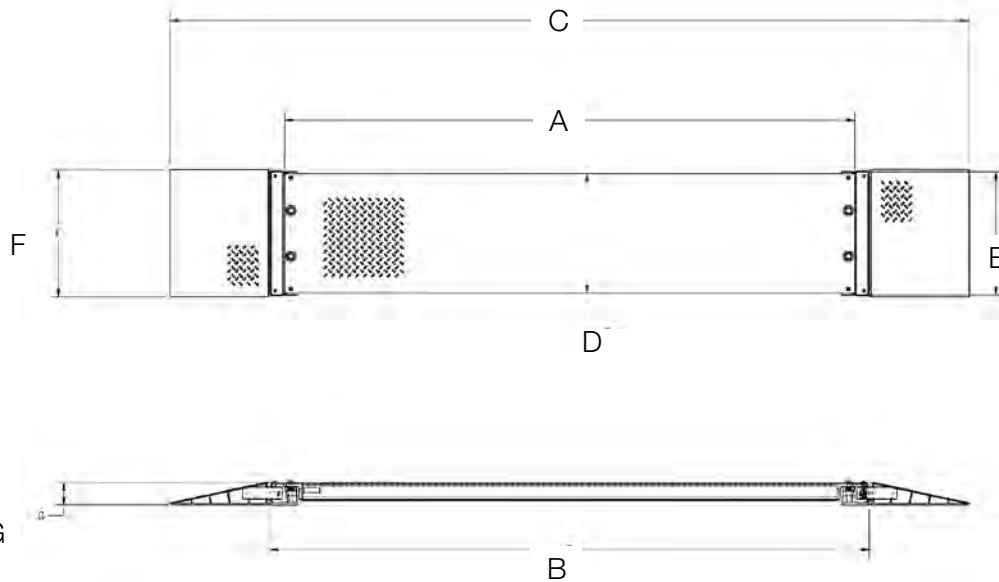

www.ricelake.com | Phone: 800-472-6703

RICE LAKE

Specifications

End Loading Capacity:
80% full scale at 50,000 lb

Warranty:
Weldment five years, load cells two years, all other components one-year limited warranty



Standard Features

- Contains four environmentally sealed, IP67 20,000 lb single-ended shear beam load cells with over braid cable
- Treaded top plate
- JB4SS TuffSeal® signal trim top access junction box
- Top access foot adjustment holes
- Carbon steel captured ball feet
- 20 ft Survivor EL147HE cable
- Non Legal for Trade
- Includes (2) 1-8NC eye bolts

Part Number/Price

Scale shown with optional ramps

Part #	Dimensions (W x L x H)	Capacity	Est. Weight	Price
Scale only				
169649	115.16 x 90 x 6 in	50,000 lb	3,350 lb	\$13,795.00
169650	115.16 x 114 x 6 in	50,000 lb	4,150 lb	\$15,525.00
169651	115.16 x 138 x 6 in	50,000 lb	5,500 lb	\$17,250.00
Scale, bundled with scale frame				
169645	120.75 x 95.75 x 6.75 in	50,000 lb	4,350 lb	\$15,020.00
169647	120.75 x 119.75 x 6.75 in	50,000 lb	5,400 lb	\$16,770.00
169648	120.75 x 143.75 x 6.75 in	50,000 lb	7,000 lb	\$18,525.00

Options/Accessories

Part #	Dimensions (W x L x H)	Est. Weight	Price
Scale frame only			
169652	120.75 x 95.75 x 6.75 in	1,000 lb	\$1,640.00
169653	120.75 x 119.75 x 6.75 in	1,250 lb	\$1,895.00
169654	120.75 x 143.75 x 6.75 in	1,500 lb	\$2,100.00
Ramp, attaches to scale frame			
169655	10 x 4 ft, single ramp	1,600 lb	\$1,840.00
169656	10 x 4 ft, ramp set	3,200 lb	\$3,680.00
Ramp, attaches to scale			
169657	10 x 4 ft, single ramp	1,675 lb	\$1,840.00
169658	10 x 4 ft, ramp set	3,350 lb	\$3,680.00

RoughDeck® AX-1

Axle Scale

TRUCK / RAIL / LIVESTOCK / AXLE SCALES

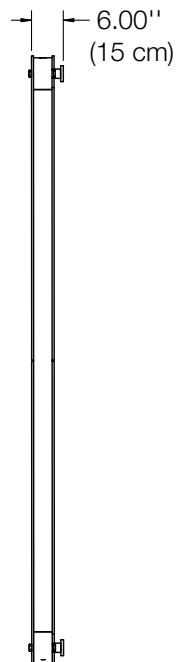
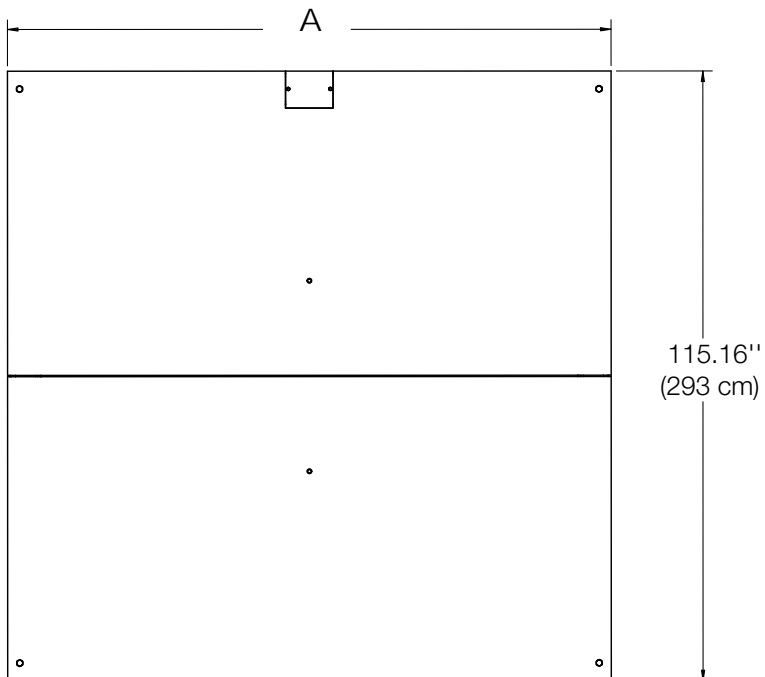

Part Number	A
169649	90 in
169650	114 in
169651	138 in

Scale

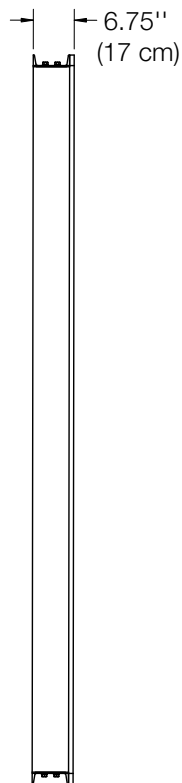
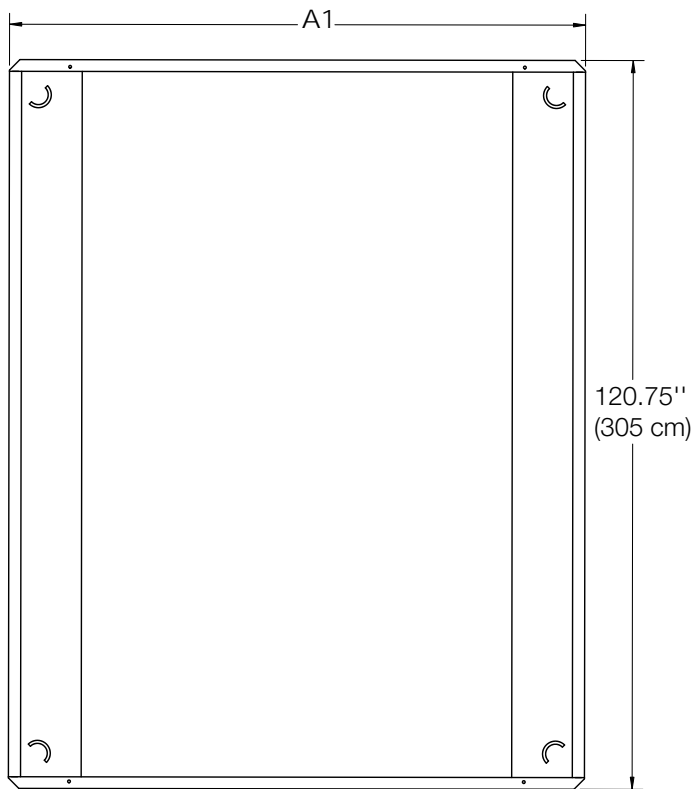

Part Number	A1
169652	95.75 in
169653	119.75 in
169654	143.75 in

Scale frame

www.ricelake.com | Phone: 800-472-6703

RICE LAKE

982

RoughDeck® AX-1

Axle Scale

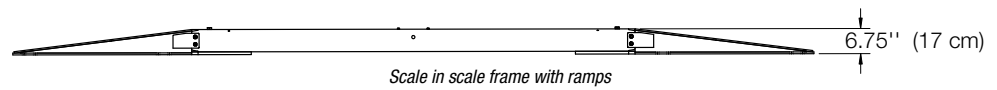
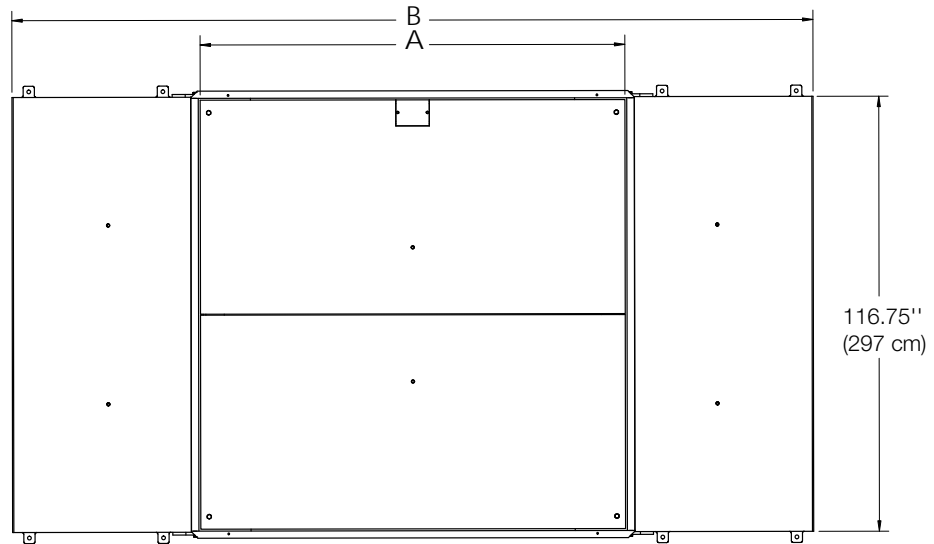

Part Number	A	B
169645	90 in	191.75 in
169647	114 in	215.75 in
169648	138 in	239.75 in

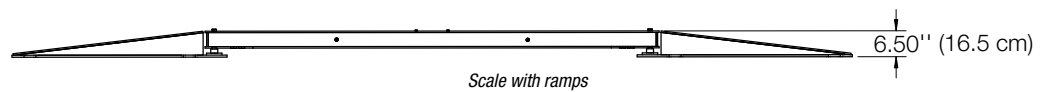
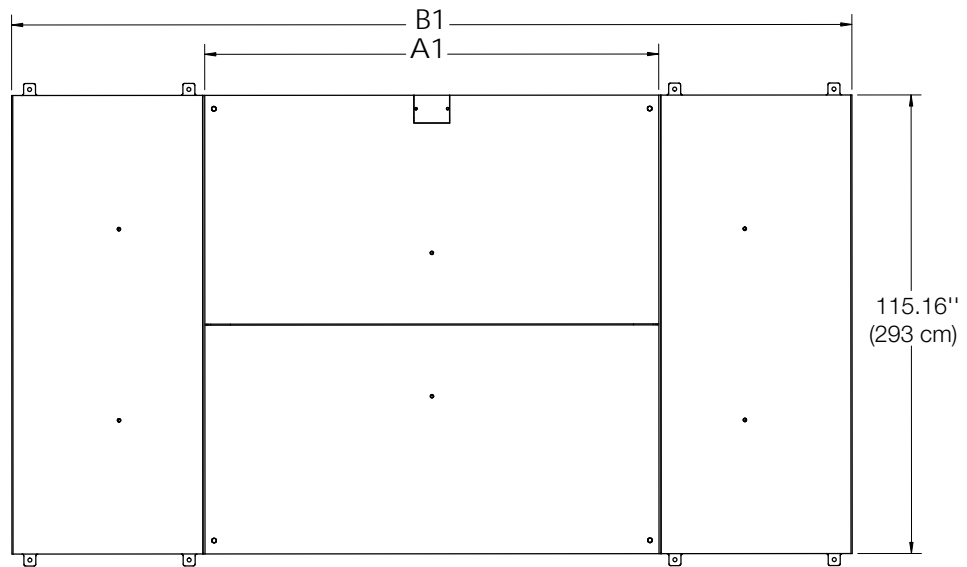

Part Number	A1	B1
169649	90 in	187 in
169650	114 in	211 in
169651	138 in	235 in

Load Ranger

Wireless Wheel Pad Scale



Standard Features

- Up to six individual pads (three sets) per system, completely wireless
- 14 individual pads (seven sets) per system maximum, joined via cable, wireless communication to indicator
- Equipped with industrial Bluetooth® radio module for ability to communicate with indicator
- Integrated wheels for easy transport and positioning
- Internal rechargeable battery with 40 hours of battery life
- Nonslip rubber on underside of platform for good grip on all types of surfaces
- Built-in indicator on each scale with 1 in character display
- IP67 rating
- Cover plate protects built-in indicator

Indicator with printer in carrying case

- Carrying case: 1 ft x 1 ft 6 in x 7 in (325 mm x 460 mm x 170 mm)
- Backlit graphic display with touchscreen technology
- Internal rechargeable battery with 10 hours of battery life
- Real-time clock
- Permanent data storage
- Slot for built-in micro SD
- 24-bit A/D converter, up to 2,300 conversions per second
- One DB9 RS-232 serial port
- Thermal printer
- ABS transport case

Wheel weighing software

- Multi-scale functioning mode with ability to weigh up to 14 individual pads (seven sets)
- Static axle weighing function, up to two channels
- Calculation of center of gravity's X and Y coordinates
- Semi-automatic tare
- Preset tare
- Selection of displayed data on LCD touchscreen
- Completely customizable keyboard
- 15 customizable and printable text IDs
- 1,000 field database
- Programmable printout from keyboard
- Print and display list of last 3,500 vehicles

Options/Accessories

- Leveling modules
- Pit frames for semi-permanent floor installations
- Aluminum ramps

Specifications

Construction:

Aluminum alloy

Display:

1 in character display on each scale

Platform Dimensions (l x w x h):

Load Ranger RF-MD: 1 ft 10 in x 1 ft 8 in x 2.28 in
(564 mm x 511 mm x 58 mm)

Load Ranger RF-WD: 2 ft 6 in x 1 ft 10 in x 2.28 in
(750 mm x 561 mm x 58 mm)

Load Ranger RF-XWD: 3 ft 1 in x 2 ft x 2.28 in
(950 mm x 611 mm x 59 mm)

Loading Surface (l x w):

Load Ranger RF-MD: 1 ft 10 in x 1 ft 4 in
(564 mm x 400 mm)

Load Ranger RF-WD: 2 ft 6 in x 1 ft 6 in
(750 mm x 450 mm)

Load Ranger RF-XWD: 3 ft 1 in x 1 ft 8 in
(950 mm x 500 mm)

System Accuracy:

0.05% of rated capacity

Power Supply:

Rechargeable battery

Approximately 40 hours of battery life

Includes uL approved AC wall adaptor US, EU and UK
100 - 240VAC input

Operating Temperature:

14°F to 104°F (-10°C to 40°C)

Storage Temperature:

-4°F to 140°F (-20°C to 60°C)

Warranty:

Two-year limited warranty

Part Number/Price

Part #	Description	Price
182099	Remote indicator with integrated printer in carrying case	\$1,595.00

Part #	Size	Graduation	Price
Load Ranger RF-MD			
181843	1 ft 10 in x 1 ft 8 in x 2.28 in (564 mm x 511 mm x 58 mm)	3,000 x 1 lb	\$1,695.00
181844	1 ft 10 in x 1 ft 8 in x 2.28 in (564 mm x 511 mm x 58 mm)	6,500 x 2 lb	\$1,695.00
181845	1 ft 10 in x 1 ft 8 in x 2.28 in (564 mm x 511 mm x 58 mm)	13,000 x 5 lb	\$1,695.00
181846	1 ft 10 in x 1 ft 8 in x 2.28 in (564 mm x 511 mm x 58 mm)	22,000 x 10 lb	\$1,825.00
181847	1 ft 10 in x 1 ft 8 in x 2.28 in (564 mm x 511 mm x 58 mm)	33,000 x 10 lb	\$1,825.00
Load Ranger RF-WD			
181848	2 ft 6 in x 1 ft 10 in x 2.28 in (750 mm x 561 mm x 58 mm)	13,000 x 5 lb	\$2,100.00
181849	2 ft 6 in x 1 ft 10 in x 2.28 in (750 mm x 561 mm x 58 mm)	22,000 x 10 lb	\$2,100.00
181850	2 ft 6 in x 1 ft 10 in x 2.28 in (750 mm x 561 mm x 58 mm)	33,000 x 10 lb	\$2,100.00
Load Ranger RF-XWD			
181851	3 ft 1 in x 2 ft x 2.28 in (950 mm x 611 mm x 59 mm)	13,000 x 5 lb	\$2,575.00
181852	3 ft 1 in x 2 ft x 2.28 in (950 mm x 611 mm x 59 mm)	22,000 x 10 lb	\$2,575.00
181853	3 ft 1 in x 2 ft x 2.28 in (950 mm x 611 mm x 59 mm)	33,000 x 10 lb	\$2,575.00
181854	3 ft 1 in x 2 ft x 2.28 in (950 mm x 611 mm x 59 mm)	44,000 x 20 lb	\$2,575.00

Options/Accessories

Part #	Description	Price
188744	RS-485 cable	\$175.00
181881	Aluminum Ramp for Load Ranger MD Models	\$245.00
181882	Aluminum Ramp for Load Ranger WD Models	\$275.00
181883	Aluminum Ramp for Load Ranger XWD Models	\$300.00

